



MAGPOWER CONTROLLER

FOR MAGNETICALLY LEVITATED PUMPS

Operating instructions

MAGPOWER Controller for magnetically levitated pumps

Welcome

Dear Customer,

You have just purchased an adixen MAGPOWER Controller. We would like to thank you and are proud to count you as one of our customers.

This product has benefited from adixen Vacuum Products 's many years of experience in the field of magnetically levitated pumps design.



In order to ensure the best possible performance of the equipment and your complete satisfaction in using it, we advise you to read this manual carefully before any intervention on your pump and to pay particular attention to the equipment installation and start-up section.

APPLICATIONS:

The MAGPOWER Controller is a digital and universal controller for magnetically levitated turbomolecular pumps, compatible with the ATHM and ATPM ranges.

This operating instruction manual includes the using instructions of the controller with an adixen maglev pump. Refer to the pump operating instructions to install the pump in the equipment ( B300).

MAGPOWER Controller for magnetically levitated pumps

This product complies with the requirements of European Directives, listed in the Declaration of Conformity contained in G 100 of this manual.

Copyright/Intellectual property:
The use of adixen products are subject to copyright and intellectual property rights in force in any jurisdiction.
All rights reserved, including copying this document in whole or any part without prior written authorization from adixen Vacuum Products.

Specifications and information are subject to change without notice by from adixen Vacuum Products.

Translated from original version

Operating instructions MAGPOWER Controller

Chapter A

INTRODUCTION

- A 100 - Introduction to the MAGPOWER controller
- A 200 - Control loop of the pump
- A 300 - MAGPOWER technical characteristics
- A 500 - Controller accessories

Chapter B

START-UP

- B 100 - Safety instructions for installation
- B 200 - Unpacking and storage of the controller
- B 400 - Safety instructions and electrical connections
- B 410 - Pump/MAGPOWER cable connection
- B 420 - Valve connections (isolation, water, air)
- B 421 - "Valves" connector wiring
- B 430 - "Remote control" connector wiring
- B 431 - Analog Output 0-10 V connector wiring
- B 440 - Heater band connection for MT models
- B 450 - RS 232 or RS 485 link wiring

Chapter C

OPERATION

- C 100 - Safety Instructions for product use
- C 200 - Controller start-up
- C 300 - MAGPOWER settings
- C 400 - Controlling the pump using the controller front panel
- C 450 - Local or remote mode operation
- C 500 - "External safety" contact operation
- C 600 - "INH" Inhibit mode operation
- C 700 - Standby mode operation "with braking" or "without braking"
- C 800 - Detailed description of RS232 and RS485 commands

Chapter D

MAINTENANCE

- D 100 - Safety instructions for product removal
- D 200 - Diagnosis and Troubleshooting

Chapter G

APPENDIX

- G 100 - Declaration of conformity, safety instructions

CAUTION

Indicates a potentially hazardous situation which, if not avoided, could result in property damage.

CAUTION

Indicates a potentially hazardous situation which, if not avoided, could result in moderate or minor injury. It may also be used to alert against unsafe practices.

Operating instructions MAGPOWER Controller

Translated from original version

WARNING

Indicates a potentially hazardous situation which, if not avoided, could result in death or severe injury.

DANGER

Indicates an imminently hazardous situation that, if not avoided, will result in death or severe injury (extreme situations).

Before switching on the appliance, study the user's manual and make sure you follow the safety instructions it gives. You can recognise these by the 'Caution', 'Warning' and 'Danger' symbols.
Good practice tips and manufacturer's recommendations are in a blue box.

The performance and operational safety of this product are guaranteed provided it is used normally in the operating conditions defined in this manual. It is the customer's task to:

- train operators to use the product if they do not speak the language the manual is written in,
- ensure operators know the safe practices to apply when using the product.



Introduction

Operating instructions MAGPOWER Controller Detailed contents

A 100

Introduction to the MAGPOWER controller

- MAGPOWER controller the new generation
- Compact and functional

A 200

Control loop of the pump

- 5 active axis
- Unbalanced force rejection control

A 300

MAGPOWER technical characteristics

- Characteristics
- Dimensions

A 500

Controller accessories

- Connection cable
- Power line cable
- Thermostated cable for thermostatic MT models

Introduction to the MAGPOWER controller



MAGPOWER The new generation of controllers

Designed for magnetically levitated turbomolecular pumps

Light and compact controller. Battery free.

Detection and automatic running of pump models:

ATH 1300 M, ATH 1600 M, ATH 1603 M, ATH 2300 M, ATH 2303 M,
ATH 2800 M, ATH 3200 M , ATP 2300 M

- ATH 1300 MT, ATH 1600 MT, ATH 2300 MT, ATH 2800 MT,
ATH 3200 MT equipped with heater band.

Convenient interface

User-friendly keypad, alphanumeric display.

Modern pump monitoring

Digital display of operating and troubleshooting parameters;

RS 232/485 serial links; Lonworks.

Power supply detection from 200 V -10%
to 240 V +10%, 50/60 Hz single phase.

Power supply for heater:

200-240 V - 50/60 Hz

Power rating: see the pump operating instructions.

Large range of interface

Dry contacts interface for status signals and optocoupled control inputs;

Selectable Analog 0-10 V output.

Introduction to the MAGPOWER controller

Compact and functional

The MAGPOWER controller is a new generation of controllers.

All functions to monitor the pumps are integrated into the controller.

Convenient interface

The front panel of the unit consists of:

Parameter selection and configuration keys

Manual control keys

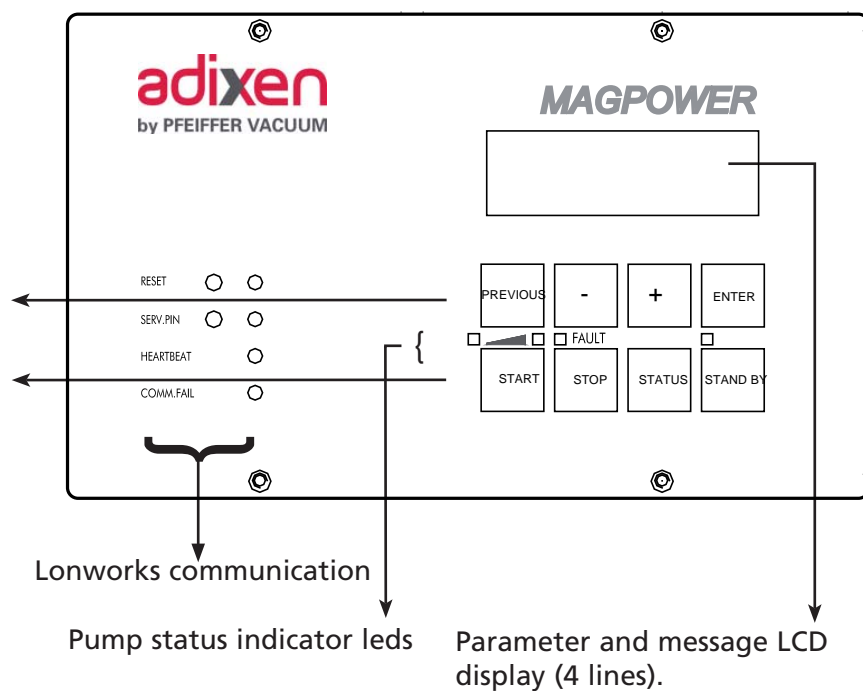

Lonworks communication

Pump status indicator leds

Parameter and message LCD display (4 lines).

Introduction to the MAGPOWER controller

The rear panel of the
unit consists of:

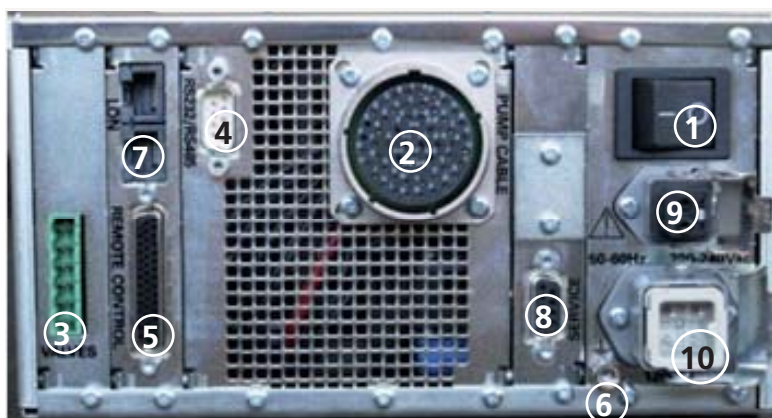

① Power switch

② Pump connector

(Wiring characteristics
on  B 410)

③ Output valves

(Wiring characteristics
on  B 420)

④ RS232/485 connector

(Wiring characteristics
on  B 450)

⑤ Remote Control connector

(Wiring characteristics
on  B 430)

⑥ Grounding

⑦ Lon Connector

⑧ Service

⑨ Thermo output

(Wiring characteristics
on  B 440)

⑩ Power supply connector

( B 410)

The output valve connector is used for the Isolation, Water and Air valve connections.

The RS232 serial link is used to control and monitor the pump using a computer.

The RS485 serial link allows the installation of many pumps in a network.

The remote control connector is used for the remote control of START/STOP/STANDBY/INHIBIT functions,

- to take in account external safeties,
- to allow the copy of pump status via dry contact outputs,
- output 0-10 V selected for the speed, the pump current or the temperature.

Allow the attachment of a grounding cable to ground the controller and connect the grounding cables of the accessories (Screw M5x6 mm).

The Lon serial link allows the installation of many pumps in a network.

Not used by customer.

The thermo output connector is used to control and power the heater band (220-240 V).

Control loop of the pump

5 active axis

The mobile assembly formed by the turbo rotor and the shaft is known as the rotor. The rotor is driven by the motor and held in suspension by magnetic fields generated by electromagnets housed in an active bearing.

The mobile rotor has 5 axes of freedom monitored by 5 active magnetic bearings.

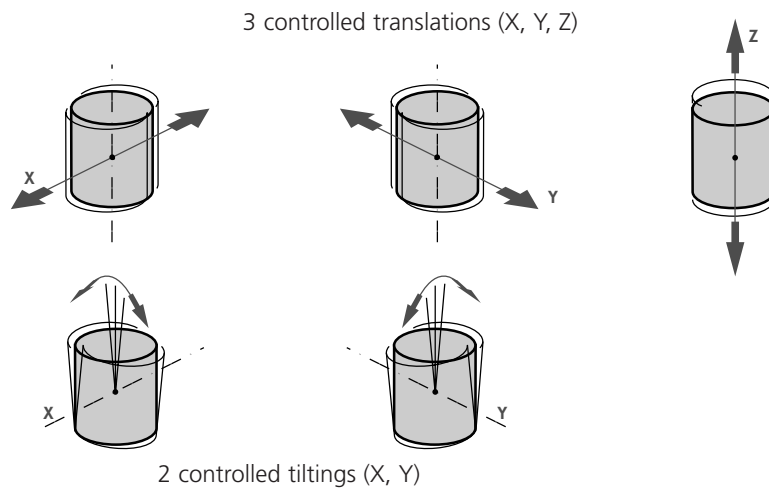

Movements in relation to these axes are monitored by position sensors. According to the position data recorded, the controller corrects differences to bring the rotor back to its optimum position, by varying the current in electro-magnets.

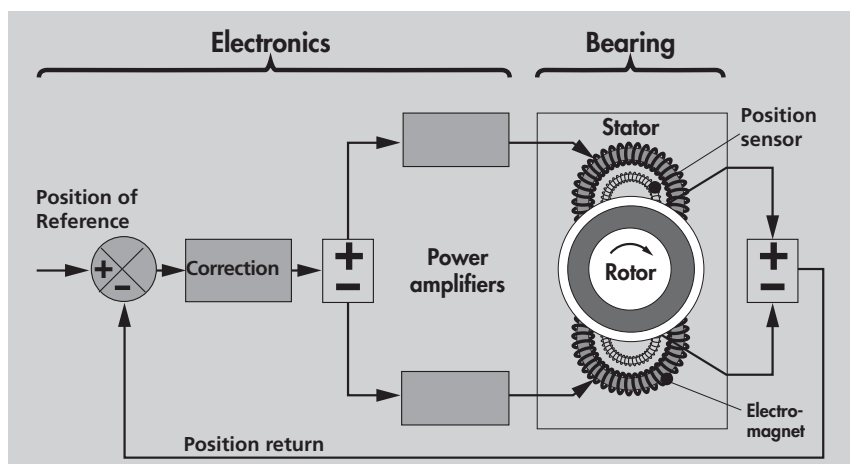

Control loop of the pump

Unbalanced force rejection control

The **unbalanced force rejection control** is an electronic function, that monitors the rotor position, allowing it to rotate in its own axis of inertia.

Changes in the rotor balance, due to deposit built-up during the life time of the pump, are automatically compensated by the **unbalanced force rejection control**.

It ensures the lowest possible levels of noise and vibration.

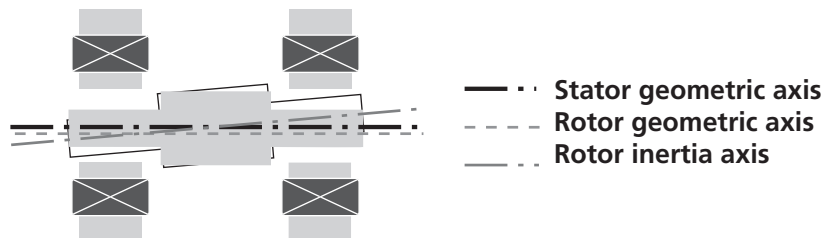

MAGPOWER technical characteristics

Characteristics

Model characteristics	MAGPOWER
Weight	8.7 kg (19 lb)
Dimensions HxWxD (mm) (inch)	132.5 x 219 x 450 5.22 x 8.62 x 17.72 1/2 Rack 19"
Power supply	
Maximum power	10 A
Nominal voltage (single phase and two-phase)	200 V -10% to 240 V +10%
Frequency	48/63 Hz
Maximum power consumption	750 W
- without heater	1.2 kW
- with heater	1.2 kW + 0.250 kW
Customer main circuit breaker rating	10 A minimum
Environnemental conditions	
Ambient operating temperature	$T \leq 40^{\circ} \text{C}$
Maximum altitude	2000 M
Maximum relative humidity	80 % up to 31 °C linear decrease up to 50 % up to 40 °C
Pollution degree applicable	2
Equipment protection	IP 20
Indoor use only	
Industrial use only	
Transient overvoltages typically present on the mains supply	
Accept temporary overvoltages on the network	Categorie II

MAGPOWER technical characteristics

Dimensions mm (inch)

Front view

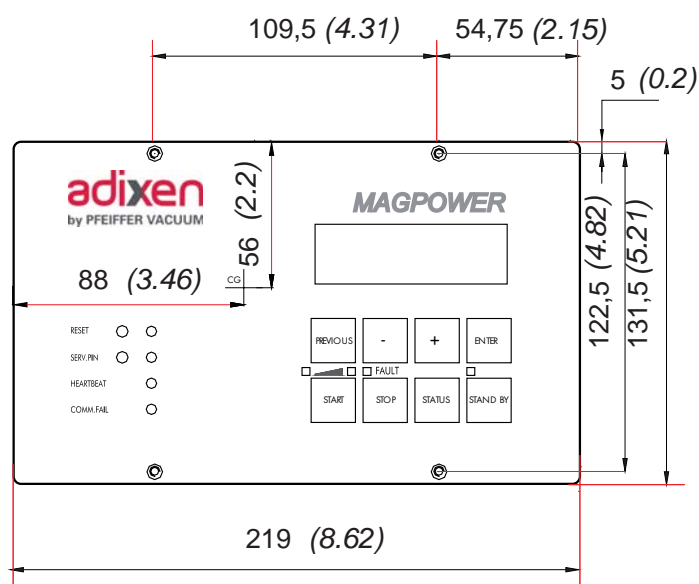

Side view

avec connecteur droit = 620 (24.40)
avec connecteur coudé = 540 (21.26)

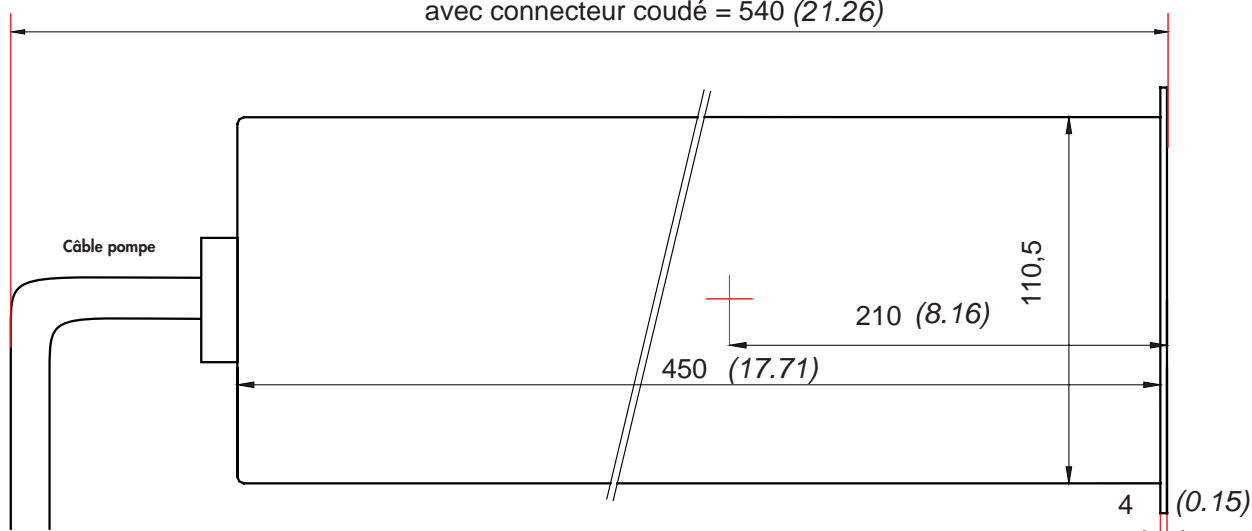

Controller accessories

Connection cable

Interconnecting cable between pump and controller.

Length	P.N.
1 m	A215300 - 010 - C6 - D
3.5 m	A215300 - 035 - C6 - D
5 m	A215300 - 050 - C6 - D
10 m	A215300 - 100 - C6 - D
15 m	A215300 - 150 - C6 - D
20 m	A215300 - 200 - C6 - D

Power line cable

Cable to connect the controller to the electrical network.

Length		P.N.
2.5 m US	230 V	A331729
2.5 m EUROPE	230 V	A328405

Thermostatic cable for thermostated MT Models

Interconnecting cable between heater band and controller.

Length		P.N.
1 m	230 V	A460082 - 010
3.5 m	230 V	A460082 - 035
5 m	230 V	A460082 - 050
10 m	230 V	A460082 - 100
20 m	230 V	A460082 - 200



Operating instructions MAGPOWER Controller Detailed contents

B 100

Safety instructions for installation

- Handling
- Installation
- Labels stuck on the product

B 200

Unpacking and storage of the controller

- Unpacking
- Controller storage

B 400

Safety instructions and electrical connections

- Electrical installation
- Connections
- Typical connections

B 410

Pump/ MAGPOWER cable connection

- On the pump connection
- On the controller
- Main power connection at the rear of the controller

B 420

Valve connections (isolation, water, air)

- Isolation valves
- Water valve (option)
- Air inlet valve (option)

B 421

"Valves" connector wiring

- Signaling using outputs
- Dry contact outputs
- Controller outputs
- Contact functional status

B 430

"Remote control" connector wiring

- The control by voltage
- The control by dry contacts with «inputs control» mode
- «Input control» mode»
- The output dry contacts

B 431

Remote control Analog Output 0-10 V connector wiring

- Remote control connector at the rear of the controller
- Analog output signal

B 440

Heater band connection for MT models

B 450

RS 232 or RS 485 link wiring

- RS 232 or RS 485 link wiring
- Serial link RS 485

Safety instructions for pump and controller installation

CAUTION	Indicates a potentially hazardous situation which, if not avoided, could result in property damage.
⚠ CAUTION	Indicates a potentially hazardous situation which, if not avoided, could result in moderate or minor injury. It may also be used to alert against unsafe practices.
⚠ WARNING	Indicates a potentially hazardous situation which, if not avoided, could result in death or severe injury.
⚠ DANGER	Indicates an imminently hazardous situation that, if not avoided, will result in death or severe injury (extreme situations).

Overview

Before switching on the product, study the Operating instructions and make sure you follow the safety instructions. You can recognise these by the 'Caution', 'Warning' and 'Danger' symbols. Good practice tips and manufacturer's recommendations are in a blue box.

The performance and operational safety of this product are guaranteed provided it is used normally in the operating conditions defined in this manual.

It is the customer's task to:

- train operators to use the product if they do not speak the language the manual is written in,
- ensure operators know the safe practices to apply when using the product.

We took care to provide you with a clean product. To keep it in this condition, unpack it only in contamination free area and at final place of use.

For emergencies

For emergencies and breakdowns, contact the manager of your local service center (see addresses at back of operating instructions or on our website).

Make sure the equipment shows no sign of transport damage. If it has been damaged, take the necessary steps to record this with the carrier and inform the manufacturer. In all cases, we recommend keeping the packaging (reusable materials) for further transport of the equipment or for prolonged storage.

Safety instructions for pump and controller installation

The turbomolecular pumps can't evacuate at atmospheric pressure, they are connected to a roughing pump. For a transient period, they can start to run at atmospheric pressure.

Our products are designed to comply with current EEC regulations. Users making their own modifications to the product are liable to break its compliance with these regulations, degrade its EMC (electromagnetic compatibility) rating, and make it unsafe to use. The manufacturer declines all liability for the consequences of such operations.

WARNING

Do not expose any part of the human body to vacuum. The product is supplied with the inlet and exhaust sealed. Remove these blanking plates when you are ready to connect the product on your vacuum system. As well as, don't operate the product unless the inlet and exhaust are connected to a vacuum and exhaust pumping line.

Handling

WARNING

- **Heavy product:**
This product needs special handling precautions due to its weight. It should be removed from its crate only by staff trained in heavy materials handling:
 - use the lifting rings provided with the product,
 - use slings from a length over 230 mm.
 - tighten the pump to the handling device.
 The maker can not be held liable for the consequences of using other rings.
- **Risk of tilting:** although the product meets EEC safety regulations , it is advisable to guard against the risk of tilting during handling, installation, and use. ( chapter A for the location of the center of gravity).

Installation

DANGER

- **Pump connection to the installation:**
It is strongly recommended to secure the maglev turbopump installation to prevent any safety hazard to the user in standard operating conditions : ( B 300).
- **Risk of cut injury:**
The access to the rotor of a turbomolecular pump with an unconnected inlet port is dangerous. In the meantime, if the pump is not switched on, it may be driven by another pump in operation.
Always connect the pump inlet port before starting the pump.

CAUTION

Make sure all parts and chambers connected to the inlet, exhaust and purge of the maglev pump can withstand a negative pressure of 1 bar below atmospheric pressure and that they are impervious to damage from vacuum (seals, etc.).

Safety instructions for pump and controller installation

Installation (cont'd)

WARNING

The user and /or OEM are ultimately responsible for operating the equipment in a safe manner. The manufacturer has no control over the types of gases exposed to this pump. This is the user and/or the OEM's responsibility to follow the necessary safety requirements.

Frequently process gases are toxic, flammable, corrosive, explosive and/or otherwise reactive.

Toxic gases can cause serious injury or death. Operators and users must take the appropriate safety recommendations to prevent injury. Consult the responsible department for instructions and safety information.

Hazardous gases through the pump can cause serious injury or death. It's mandatory by regulations to connect the turbomolecular pump's exhaust to a rough pumping line compatible with the process gases. Check that pump is correctly connected to the equipment ( B310).

DANGER

■ If any corrosive, reactive, flammable, pyrophoric, oxidizing process gases can be sent to the pump, then an exhaust extraction system monitor should be used to ensure that gas flow to the pump is stopped when exhaust gas extraction system is lost.

If flammable materials are sent to the pump, the customer will need to provide a hardware based LEL detection in the exhaust extraction system (detection capability at 25% of the LEL) that will stop chemical supply to the pump when gas is detected over 25% of LEL for that flammable material.

■ For non clean process.

If loss of purge flow creates a significant risk, then the purge flow must be monitored externally and a response to loss of purge flow must be provided by the process equipment and interlocked.

If pyrophoric materials above the LEL (lower explosive limit) are sent to the pump then nitrogen should be supplied at a rate to ensure that concentration is diluted to be below the LEL, in addition an interlock should be provided to ensure that gas flow to the pump is stopped when nitrogen is lost.

CAUTION

■ The product's EMC rating is obtained on the understanding that it is installed in compliance with EMC rules.

Specially: in environments that are prone to emit interference, use shielded cables and connections on interfaces.

■ Ensure that the product is connected to an electrical installation:

- in compliance with the local and national safety requirements,
- equipped with electrical protection (fuses, circuit breaker, ...) which has a suitable earth (ground) point, properly connected.

■ This pump is not equipped with a lock out/tag out (LO/TO) device because it is designed for use on process tools.

In order to properly secure the pump for installation or/and maintenance, the entire tool needs to be properly locked-out/tagged out in accordance with OSHA requirement 29 CFR.1910.147.

■ If access to the IEC connector is restricted an additional isolation device should be provided, which will be easily accessible by an operator.

Safety instructions for pump and controller installation

Installation (cont'd)

 WARNING**■ Electric shock hazard.**

The voltages and currents in use can induce electric shock.

Isolate and lock out power line to the product before maintaining it /or removing the cover.

Only skilled, authorized people may carry out maintenance work.

If a main isolator is installed by the customer, it must be in compliance with local regulations, with a minimum interrupting short circuit current of 10kA.

■ Electric shock hazard.

Some components have capacitors charged to over 60VDC, or motor operating as generator. When power is switched off, they keep their charge for a time. Take precautions concerning the access to the connector pins. Wait at least 5 minutes after the pump comes to complete stop before starting any work.

■ Other located hazardous energies.

Water cooling circuit and nitrogen purge are pressurized hazardous energies.

Release pressure before servicing:

1 - for the N2 purge, disconnect the gas line ;

2 - for the water cooling circuit, disconnect the input connector and leave the output connected. Don't forget to put a vessel (≥ 1 l) under the water output.

■ Operation in local mode

There is no device to warn that the pump operates in local mode. When the pump is not integrated in the equipment/host tool, the user must provide a device to warn that the pump operates in local mode.

■ The products are factory tested to ensure they will not leak in normal operating conditions. It is the user's responsibility to ensure this level of leak tightness is maintained.

■ Specific operating conditions may exist that require extra caution from users due to the high temperatures generated (outer surfaces $> 70^{\circ}$ C):
Wear protective gloves and leave the pump to cool before working on the product.

Safety instructions for pump and controller installation

Installation (cont'd)

DANGER

Safety interlock.

The pump motor is protected against overload through the drive «start/stop» and enable control circuitry of the variable speed controller. The drive start/stop includes solid state components. If hazards due to accidental contact with moving machinery or unintentional flow of liquid, gas or solids exist, an additional hardwired stop circuit is required to remove input power.

It is never required to override this interlock during installation, use or maintenance.

Once activated power will be switched off and the pump will be put in a safe condition. When a fault occurs, the cause must be corrected before the fault can be cleared. It is required to switch power off and on to clear the fault.

CAUTION

■ If the product is used in applications where solid particles or condensable gases are present, we advise on avoiding any deposition into the pumping line. Contact our customer service.

■ The manufacturer guarantees the right operation of the pump if it is used in a uniform magnetic field up to 0.5 mT.

From 0.5 to 5 mT the limit of the right operation depends on the cooling and the gas loads.

Exceeding 5 mT can cause excessive rotor heating due to the eddy generated currents. It is therefore necessary to provide suitable shielding in such cases. The pump standalone is resistant to radiation at levels up to 10^3 Gy.

■ The units containing control circuits are designed to guarantee normal safety conditions taking their normal operating environment into account (use in rack).

In specific cases of use on tables, make sure that no objects enter the ventilation openings or block the openings when handling the units.

■ Protection against foreign bodies

Controller can be deteriorated when any objects are introduced or any liquids penetrate into the unit.

Make sure no objects enter through the ventilation holes. Keep the unit away from the liquids.

Safety instructions for pump and controller installation

Labels stuck on the product

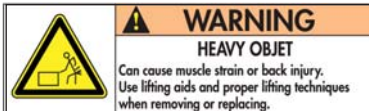

This label indicates that handling the pump can cause muscle strain or back injury. For all product handling, use the appropriate handling devices.

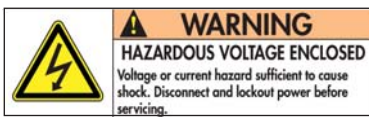

This label indicates that some of the internal parts are energized and could cause electrical shocks in case of contact. It advises to disconnect the pump before any intervention or to properly lock-out and tag-out the equipment breaker before any intervention on the pump.

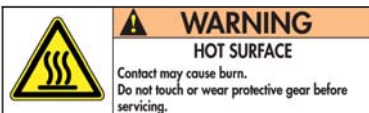

This label warns the user against possible risk of injury due to any hand contact with hot surfaces. It states that protective gloves should be used before performing any intervention.

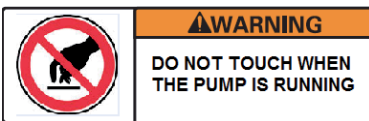

Avoid causing a shock on a pump when the rotor is moving, it can block the right operation.

Other labels

Customer is in charge to stick these labels on the ATHM on the most appropriate location to warn the operator regarding the probable hazards.



This label informs the user that moving parts present inside the pump could cause personal injury, like crushing or cutting. The user must keep all body parts away from moving parts.

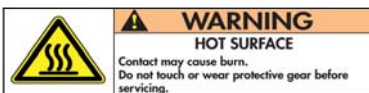

The «hot surface» sticker must be stucked conspicuously on the pump housing.



The user must label visibly the product to warn against pumped process gas that could be dangerous and toxic and could cause severe injuries or death. It specifies that any preventive maintenance operation can only be performed by trained personnel.

Unpacking and storage of the controller

Unpacking

Make sure the equipment shows no sign of transport damage. If it has been damaged, take the necessary steps to record this with the carrier and inform the manufacturer. In all cases, we recommend keeping the packaging (reusable materials) for further transport of the equipment or for prolonged storage.

To keep your product in the clean condition in which it left our factory, we recommend that the controller be unpacked at his assembly site.

⚠ WARNING

Risk of tilting: although the product meets EEC safety regulations , it is advisable to guard against the risk of tilting during handling, installation, and use. (refer to chapter A for the location of the center of gravity).

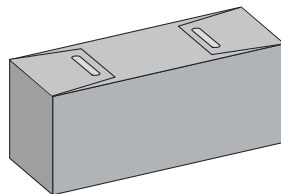

Controller

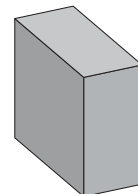

Electrical cable

Controller storage

CAUTION

The controller can be stored in its cardboard box in the following conditions:

- in a clean and dry environment,
- at an ambient temperature between - 5°C (23°F) and +50°C (122°F),
- for a period of 1 year maximum.

When it is unstored, let it a an ambient temperature during 24 hours before using it.

Safety instructions and electrical connections

Study the preliminary precautions ( B 100).

CAUTION

- The pump is Class 1 equipment and therefore must be earthed. The user must check the electrical installation to which the product is connected:
 - it must comply with current standards (IEC 364),
 - it must have a standards compliant earth wire, properly connected to earth.
- If access to the IEC connector is restricted an additional isolation device should be provided, which will be easily accessible by an operator.
- Ensure that all electrical wiring is safely secured so that people cannot trip on them.
- Differential circuit breaker

In case of insulation defect, for personnel protection you must install on the main power supply a type B differential circuit breaker GFI (or RCD) of 30mA. This equipment protection device is compatible with type T.T electrical network. For other network type T.N or I.T, apply the right protection device. Contact adixen product manufacturer for advice.
In all cases, comply with current local regulations.

WARNING

- Installation protection with circuit breaker
The user must supply the product from facilities equipped with 10 A main circuit breaker, curve D or C (IEC 60947-2), in accordance with local regulations and with a minimum short circuit interrupting current of 10 kA.
- This protection device should be in close proximity to the pump (no further than 7m (25 ft) within line of sight of the pump.
This pump is not equipped with an emergency stop EMO device because it is designed for use on process tools and integration with the process tool EMO.
Check that the pump is correctly connected to the equipment emergency stop device.
- The controller is connected:
 - to the main power with a main cable separately delivered,
 - to the pump with the interconnection cable.Voltage and current are present on these cables and on the heater power line (if installed).
Avoid to pinch or pull these cables and route them safely.
- Risk of electric shock:
Make sure that main switch is off during electrical connection.
Disconnect any main power sources from the product prior to servicing.

Safety instructions and electrical connections

CAUTION

An IEC 417#5019 symbol is located on the rear panel. 

DANGER

Electric shock hazard.
 The voltages and currents in use can induce electric shock.
 Isolate and lock out power line to the product before maintaining it /or removing the cover.
 Only skilled, authorized people may carry out maintenance work.
 If a main isolator is installed by the customer, it must be in compliance with local regulations, with a minimum interrupting short circuit current of 10kA.

Electrical installation

The unit must be installed in an environment ventilated either by natural convection or by the movement of forced air. Cooling is normally performed by an internal fan which ventilates air from the inside to the outside of the unit.

CAUTION

Controller ventilation
 Internal components can be damaged through overheating if there is inadequate ventilation:
 - don't use the controller at an ambient temperature above 40 °C,
 - do not block the ventilation holes,
 - leave 50 mm (2 inch) free space above, below and behind the controller,
 - install it at a height between 1.64 m (64.5 inch) and 0.28 m (11 inch) from the floor.

Connections

Connect the RS232 or RS485 serial link to this connector ( B 450)

Connect the controller to the pump ( B 410)

(pump model MT)
 Connect the heating band (220_240 V) on the pump, and lock the connector ( B 440).

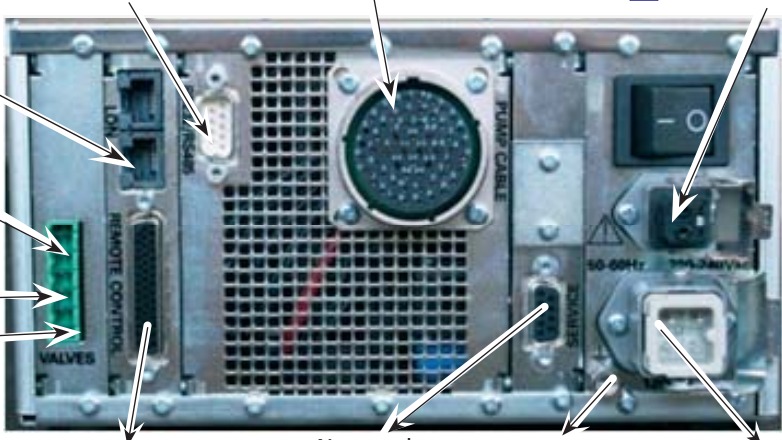

Connect the controller to the power supply, and lock the connector ( B 410)

LON Connectors

Isolation
 This isolation valve is driven by a dry contact ( B 420)

Water

Air
 This outputs valves are driven by the controller (24 V DC) ( B 420)

Not used

Grounding

Make various connections if dry INPUTS/OUTPUTS are used ( B 430), if not use the plug connector

Safety instructions and electrical connections

Typical connections

In this installation, we use:

- a roughing isolation valve V1 between the turbo pump and the roughing pump;
- a high vacuum isolation valve V2 between the turbo pump and the chamber to be pumped;
- a relay K1, their contacts drive the valve V1 and the roughing pump power supply;
- the thermostatic option (MT pump model).

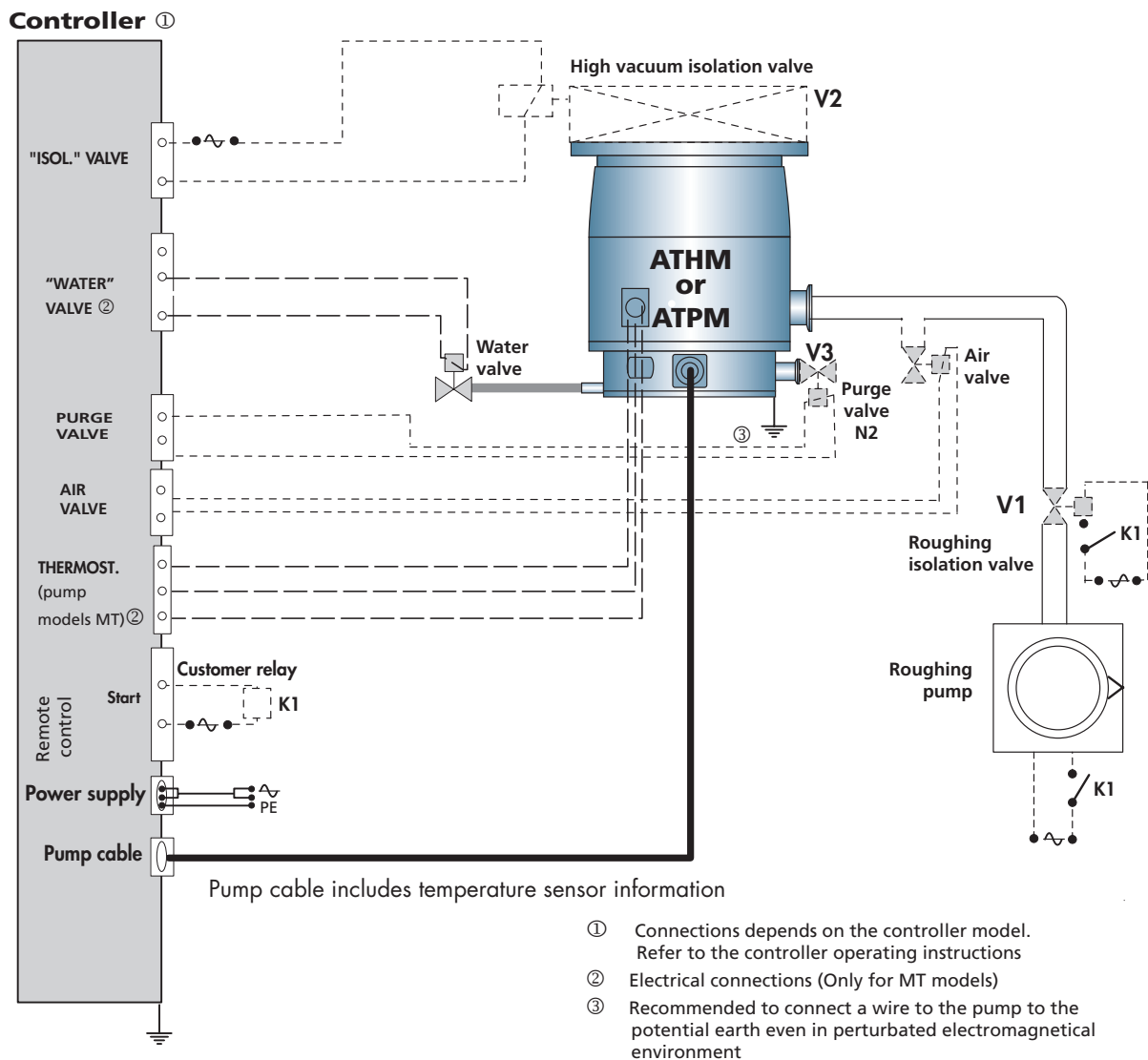

Wiring diagram (typical)

Legend:

- Minimum electrical connections
- - - Optional electrical connections recommended by the manufacturer (version M only)
- - - Electrical connections (version MT only)

Pump/MAGPOWER cable connection

Connection between pump and controller

On the pump connector

1 - On the pump connector, identify the main index on the pump connector.



2 - Then identify the main index on the cable connector.



3 - Insert the connector in accordance to the main index and then, press the bayonet type connector axially into place and rotate the bayonet ring at the same time until it locks into position (feel the « click »).

If it is difficult to press and rotate, remove the connector and check the pins on the pump connector (bent pins).

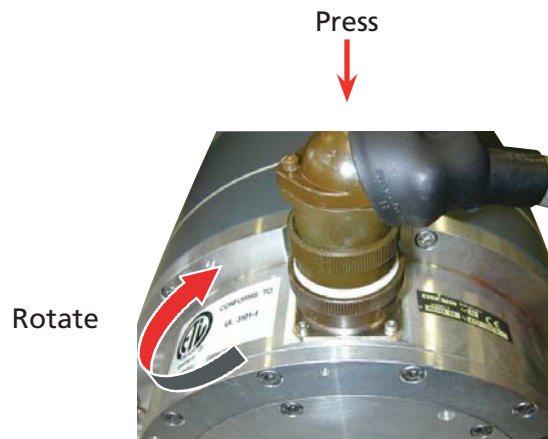

Pump/MAGPOWER cable connection

On the controller



Connect the cable on the connector according to the following instructions.

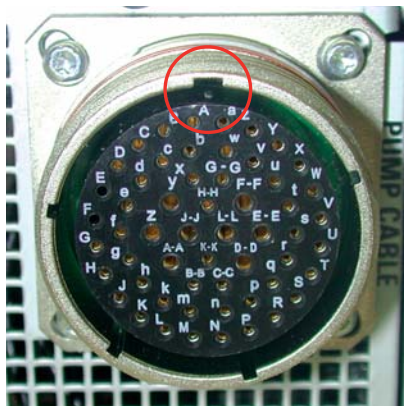

Locate the main index on the controller connector.

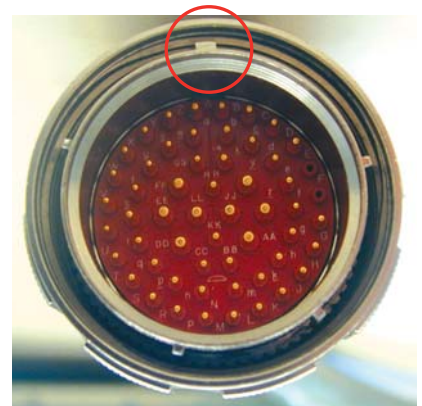

Locate the main index on the cable connector.

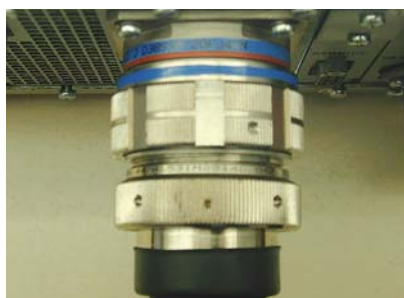

Insert the connector in accordance to the main index and then, rotate the ring until the red part isn't visible (only blue color is visible).

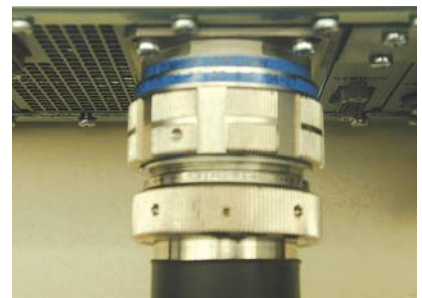

The connector is locked.

Pump/MAGPOWER cable connection

Main power connection At the rear of the controller

Check that the seal is available on the controller connector.

Identify the main index.

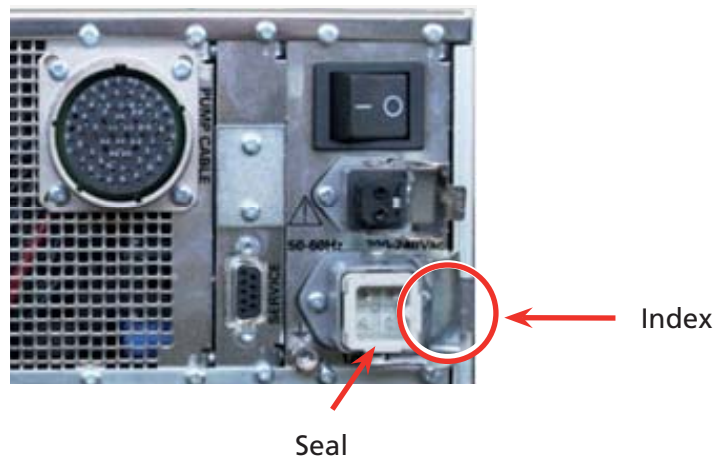

Identify the main index on the female HARTING connector.

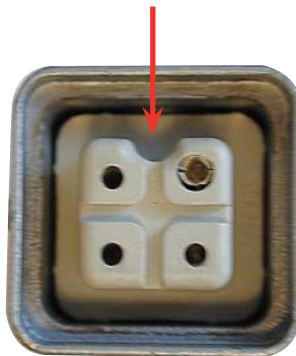

Plug the female connector in accordance to the main index, and lock the connector.

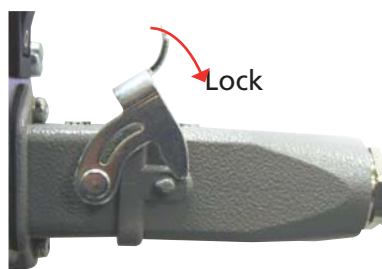

Valve connections (isolation, water, air)

Isolation Valves

⚠ WARNING

When units containing control circuits are equipped with dry contact outputs, it is the responsibility of the customer to use these outputs in compliance with extra low voltage installation and safety standards (SELV). It concerns Remote, Profibus and RS connectors except main power connector.

At inlet: high vacuum isolation valve

⚠ CAUTION

It is recommended to install an isolation valve NF type (closed out of voltage) between the chamber to be pumped and the pump inlet to maintain the pressure in the chamber while the pump is reset to atmospheric pressure.

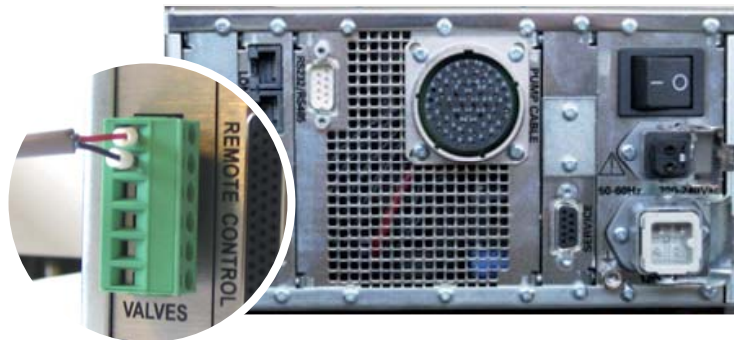

When the controller detects a bearing operating fault, it opens the contact.

After a stop, it opens when the rotational speed reaches 10000 rpm.

This contact can be used to control a high vacuum isolation valve which is used to maintain the pressure in the chamber while the pump is reset to atmospheric pressure.

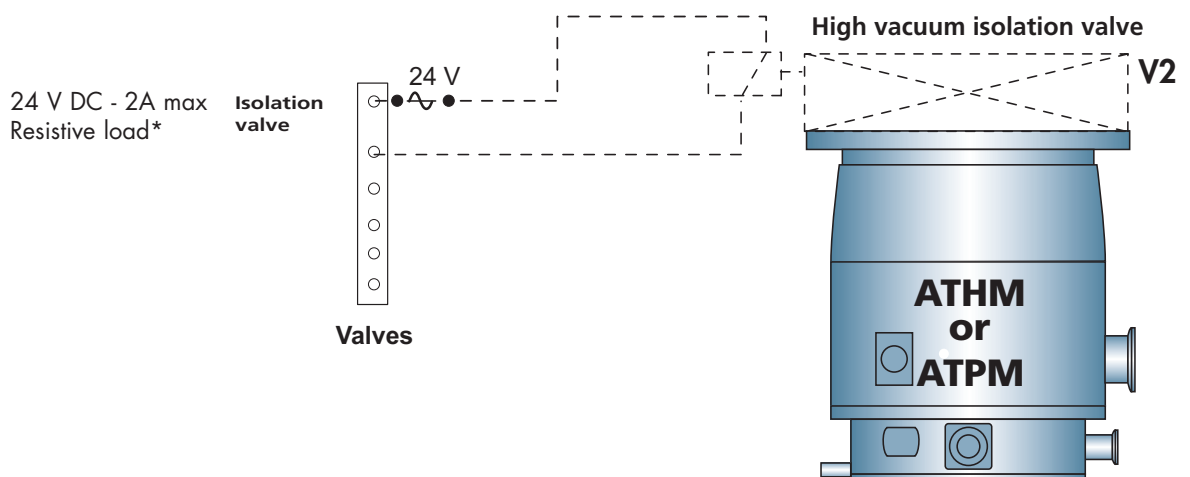

* if inductive load, use a wire connector with protection.

Valve connections (isolation, water, air)

Isolation Valves (cont.)

At exhaust:
roughing isolation valve

CAUTION

It is highly recommended to install an isolation valve (closed when power is off) between the turbo pump and the roughing circuit.

The valve is open using the « START » contact on the controller. If the valve is missing, the time taken to slow down in the event of an accident, is increased, thereby reducing the service life of the back-up bearings.

Connect this valve as close to the pump exhaust as possible.

Connect the valve to the roughing pumping circuit.

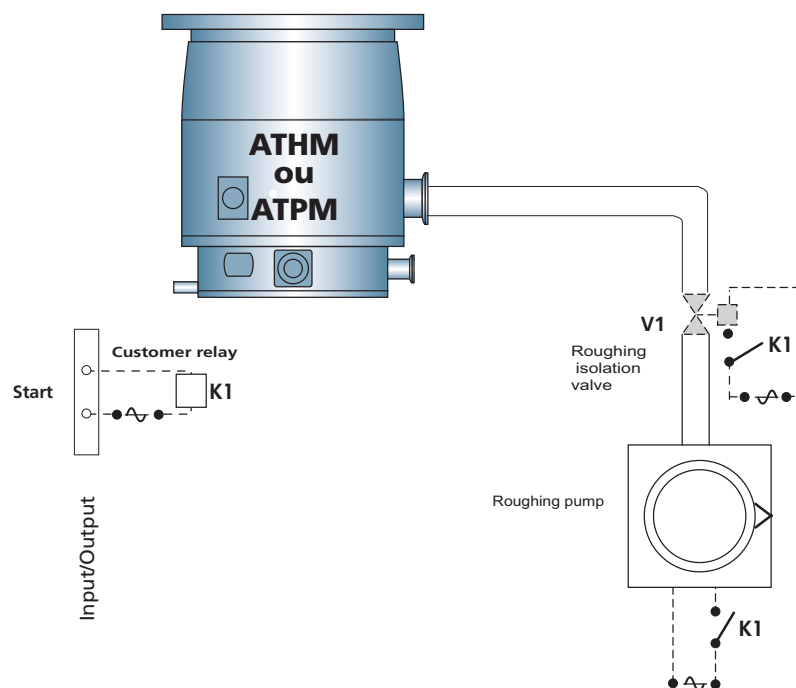

Valve connections (isolation, water, air)

Water valve
(optional)

CAUTION

Do not mount water fittings above electrical components in case of a leak at the water fitting connection.

Electrical connection Temperature is regulated by the controller.

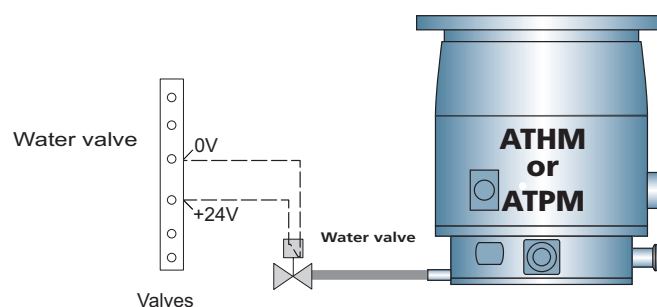

Connect the water valve to the «valves» connector. The temperature is regulated by a sensor integrated inside the pump ( B 440).

«Water» valve output
24 V DC

The voltage delivered on this output depends on the pump temperature and the selected temperature.
I max: 500 mA.

Valve connections (isolation, water, air)

Air inlet valve (option)

Electrical connection

Connect the valve (24 V DC) powered and driven by the controller via the «AIR VALVE» contact on the Dry Contact connector ( B 421).

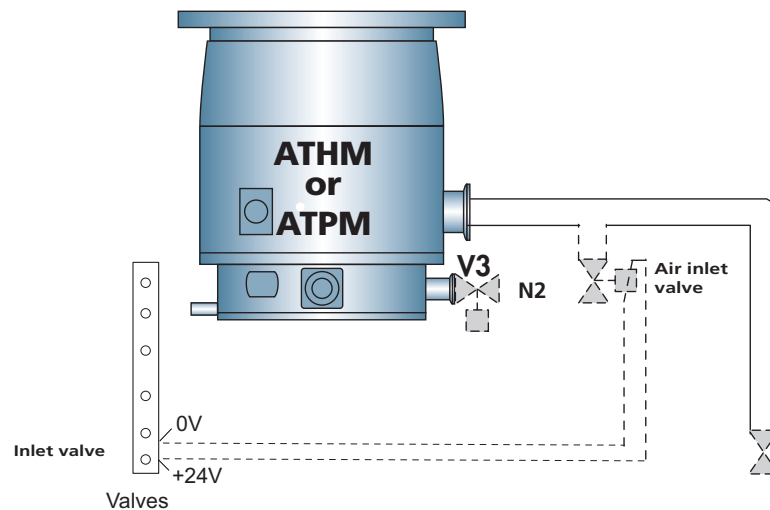
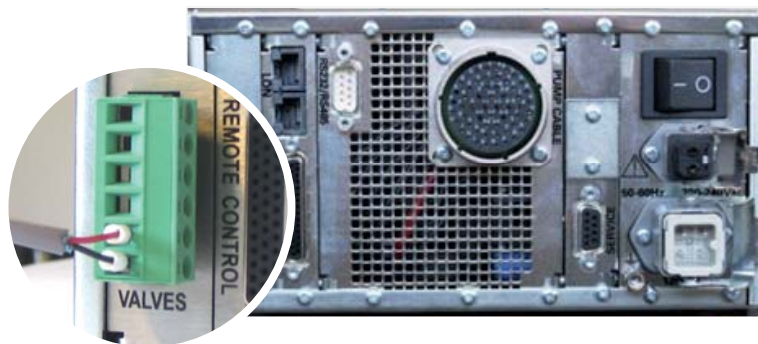

«Air» valve output 24 V DC

The voltage is delivered on this output during the «venting time» according to the configuration ( C 450).

I max: 250 mA.

"Valves" connector wiring

WARNING

When units containing control circuits are equipped with dry contact outputs, it is the responsibility of the customer to use these outputs in compliance with extra low voltage installation and safety standards (SELV). It concerns Remote, Profibus and RS connectors except main power connector.

Signaling using outputs

Used to copy the data concerning the pump operating status.

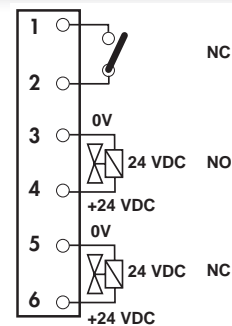

Valves

Dry contact outputs 24 V DC - 2A

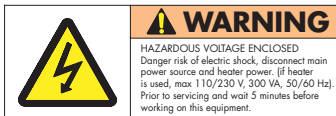

Isol. valve 1 - 2 (NC)	When the controller detects a bearing operating fault, it opens the contact. After a stop, it opens when the rotational speed reaches 10000 rpm. This contact can be used to control a secondary isolation valve which is used to maintain the pressure in the chamber while the pump is reset to atmospheric pressure.
---------------------------	--

Controller outputs 24 VDC

Water valve 3 - 4 (NO)	The voltage is delivered on this output depending on the pump temperature and the selected temperature.
Air valve* 5 - 6 (NC)	The voltage is delivered on this output during the "Venting time" according to the configuration ( C 450).

* Stop / Ext. fault functions allow to close the contacts at 10000 rpm + setted delay.

Contact functional status

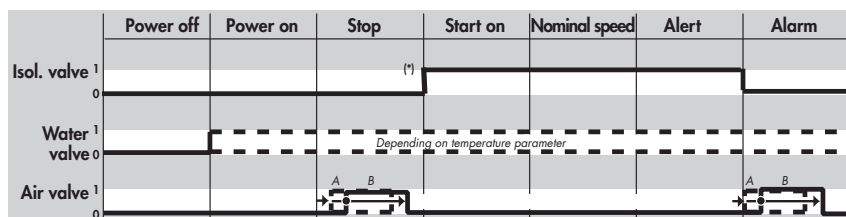

(*) After a STOP: ISV opens when the rotation speed is below 10000 rpm.

AIR VALVE opens when the rotation speed is below 10000 rpm.

(A) Time before valve opening (Time to venting different of 0). To modify the time see C300.

(B) Time of valve opening (Venting time different of 0). In both cases, the air valve closes

when the rotation speed reaches 0 rpm. To modify the time see C300.

“Remote control” connector wiring

⚠ WARNING

When units containing control circuits are equipped with dry contact outputs, it is the responsibility of the customer to use these outputs in compliance with extra low voltage installation and safety standards (SELV). It concerns Remote, Profibus and RS connectors except main power connector.

⚠ CAUTION

In the case of a local mode operation of the controller, the pump will run only if the terminal plug (delivered with the controller) is connected on the “Remote control” connector.

Terminal plug type DB 44 contacts male connector

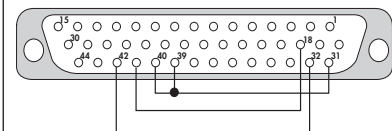

Factoring wiring (Soldered-side view)

The control by voltage

The “Remote control” connector is located at the rear of the controller (DB 44 contacts, female connector). The inputs are considered to be activated if the DC voltage applied is between 10 and 24 Volts (fig 1).

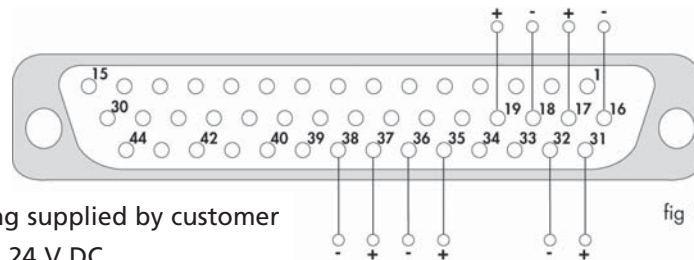

Wiring supplied by customer
10 to 24 V DC

fig 1

The control by dry contacts with “input control” mode

These inputs can be controlled by customer equipment external contacts (fig 2).

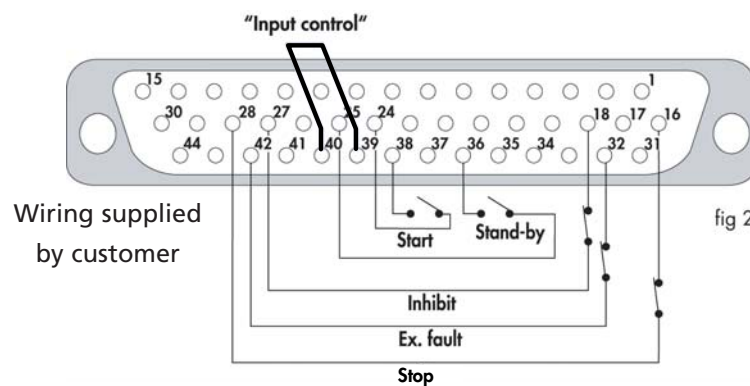

Wiring supplied by customer

fig 2

It is necessary to read the following tables for more information.

"Remote control" connector wiring

"Input control" mode

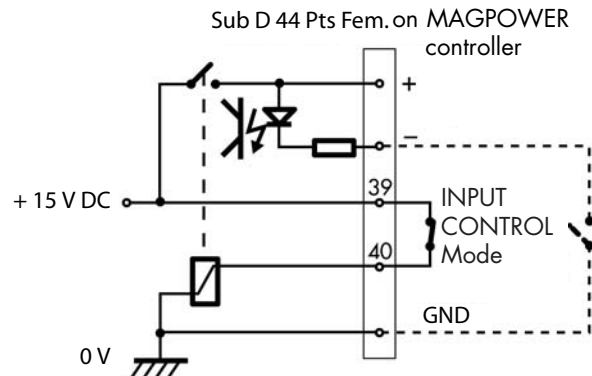

	Function	Command mode			
		Voltage 10 V/ 24 V DC	Dry contacts "Input control" mode (Strap 39-40) ⁽¹⁾		
INPUTS	Remote function if "Remote" mode selected	Remote start	37(+) 38(-)	38(-) GND	<ul style="list-style-type: none"> - "Remote stop - Ext. fault - Inhibit" inputs must be valid. - The "Remote start" allows pump starting when an impulse or a permanent action is applied on this input.
		Remote stop	17(+) 16(-)	16(-) GND	<ul style="list-style-type: none"> - When the input is disabled, the motor is stopped by impulse or by permanent action. - Restart the pump as follows: <ul style="list-style-type: none"> - disable "Remote start" - valid "Remote stop" - valid again "Remote start"
		Remote standby	35(+) 36(-)	36(-) GND	<ul style="list-style-type: none"> - When the "Standby" is validated, the rotational speed corresponds to the selected speed (C 300). - When the "Standby" is disabled, the rotational speed corresponds to the nominal speed.
	Independent of the "Remote" mode (safety)	External fault	31(+) 32(-)	32(-) GND	<ul style="list-style-type: none"> - When the "External fault" input is disabled the motor is stopped. Actions on the start, stop key (or remote) are deactivated. - Restart the pump by validating the input "Ext. fault", and activate the "Start" (key or remote).
		Inhibit	19(+) 18(-)	18(-) GND	<ul style="list-style-type: none"> - When the "Inhibit" is disabled, the controller doesn't supply the motor and inhibit the progressing function. There is no air inlet, the actions on the start, stop (key and remote) are deactivated. - When "inhibit" is valid, the controller powers the motor and restores the previous operating status.
		24, 25, 26, 27, 28, 29, 41, 42		Ground	

(1) "Input control" mode: by strapping terminals 39-40, all the (+) terminals are supplied with 15 VDC. Connect the (-) terminals to the dry contact and to the ground.

“Remote control” connector wiring

The output dry contacts

Sub D 44 Pts Fem. on MAGPOWER

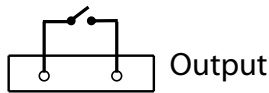

Dry contact
24 V DC - 2A max
Resistive load

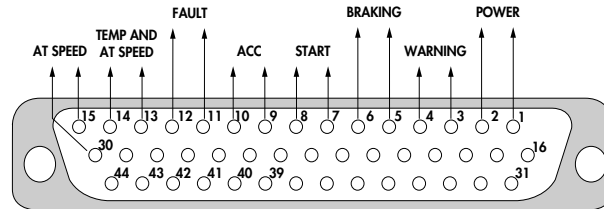

The output dry contact functions is to copy the data concerning the pump status.

OUTPUT	Independent of the “Remote” mode (safety)	Power	1 - 2	- The POWER contact is closed following the power-up and after approximately 20 seconds. In case of power failure, this contact opens below 10000 rpm.
		Warning Temperature	3 - 4	- The WARNING contact is opened when the pump temperature reaches alert threshold. It remains open when the pump temperature is greater than the alarm threshold. - The WARNING contact closes at temperature below the alert threshold minus 2°C (Hysteresis).
		Braking	5 - 6	- The BRAKING contact is closed when the pump decelerates to reach zero speed following a STOP, INHIBIT, or EXTERNAL FAULT action. The BRAKING contact is always open below 400 rpm. - The BRAKING contact is opened after a START action.
		Start	7 - 8	- The contact is closed when the START control is activated on the controller. The contact can be used to control a primary isolation valve and via a power relaying device, to control the primary pump.
		Accelerating	9 - 10	- The ACCELERATING contact is closed when the motor is in acceleration phase with a speed over 400 rpm. It remains closed until the selected speed is reached. - The ACCELERATING contact is open when a STOP, INHIBIT, or EXTERNAL FAULT action is taken into account.
		Fault	11 - 12	- The FAULT contact is open following the appearance of any fault (external, temperature, frame, motor, etc...). - The contact is closed if there are no faults.
		At speed and thermostatic temperature	13 - 14 **	- The AT SPEED and THERM. TEMP contact is closed when the selected speed is reached or when the pump is in overspeed mode (in the event of modification of reference speed), and when the temperature is greater than the heating temperature minus 3°C (if thermostatic temperature setted “ON”). - The AT SPEED and THERM. TEMP contact is opened when a STOP, INHIBIT, or EXTERNAL FAULT action is taken into account, or when the pump temperature is not reached, or when the speed decreases under the threshold “relay speed” selected*.
		At speed (only)	15-30 **	- The AT SPEED contact is closed when the selected speed is reached or when the pump is in overspeed mode (in the event of modification of reference speed), - The AT SPEED contact is opened when a STOP, INHIBIT, or EXTERNAL FAULT action is taken into account, or when the speed decreases under the threshold “relay speed” selected*.

* This threshold can be set between - 3% and - 50%. It can be accessed on the front panel using the “set up” and “relay speed” menu.

** See C 700.

Remote control Analog Output 0-10 V connector wiring

Remote control connector at the rear of the controller

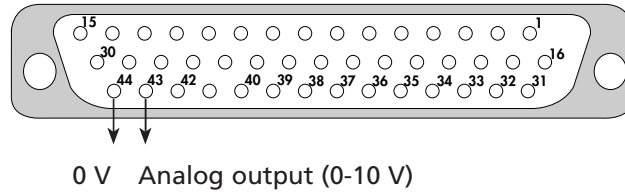

Analog Output 44 - 43	Used to monitor the selected parameter (see ANALOG OUT menus C 300).
----------------------------------	---

Analog output signal

The signal is transmitted between terminals 44 and 43 of the remote connector.

Four values can be used to plot curves:

	Output	
	0 V	10 V
Pump rotational speed *	360 rpm	60000 rpm
Pump temperature	0° C	100° C
Controller temperature	0° C	100° C
Current	0 mA	15000 mA

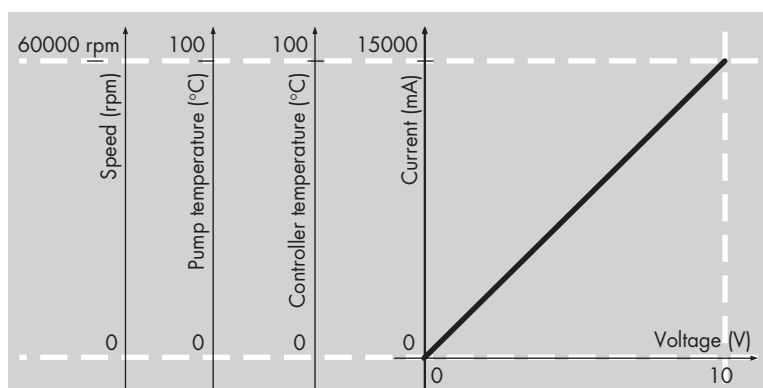

Factory configuration is set to speed.

The pump rotational speed depends of pump models. See the operating instructions of the pump.

Heater band connection for MT models

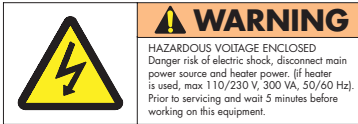

WARNING
 HAZARDOUS VOLTAGE ENCLOSED
 Danger risk of electric shock, disconnect main power source and heater power. (if heater is used, max 110/230 V, 300 VA, 50/60 Hz). Prior to servicing and wait 5 minutes before working on this equipment.

Voltage or current hazard are sufficient to cause shock. Disconnect and isolate power before servicing.

These pumps are equipped with a heater band, a thermal sensor and a water valve to regulate the temperature.

The body of the pump can be heated to 75° C to avoid gas condensation in the pump during semiconductor processes.

Connection Connect the thermostatic cable as follows:



Heater band temperature Temperature is regulated by the controller.

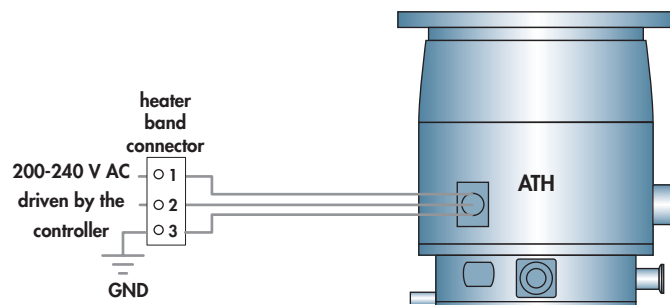

Heater band connection for MT models

The temperature can be chosen on the controller (between 31 and 75° C or OFF).

By choosing «OFF» temperature, the heater band is switched off and the pump is cooled permanently.

The temperature of the pump can be read on the display of the controller ( C 300).

On certain types of pumps, a thermostat is integrated and switches off the power supply of the heater band at pump body temperature is > 100° C.

The thermostat is manually reset from the outside of the pump.

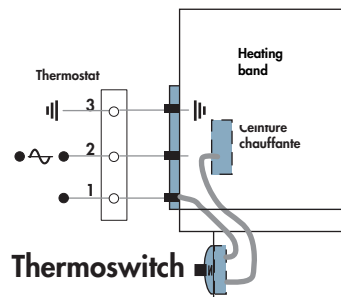

The «hot surface» sticker must be stuck conspicuously on the pump housing.



Hot surfaces are identified by a label-stuck on hot surfaces. The pump housing temperature can reach 75° C. Contact may cause burns. Do not touch. Alternatively, protective gloves may be worn when servicing the product.

RS 232 or RS 485 link wiring

The initial configuration of the serial link is as follows:

- Type: **RS 232**
- Transmission speed: **9600 bauds**
- Data length: **8 bits**
- Parity: **NONE**
- Stop bit: **1**

RS 232/485 connector wiring

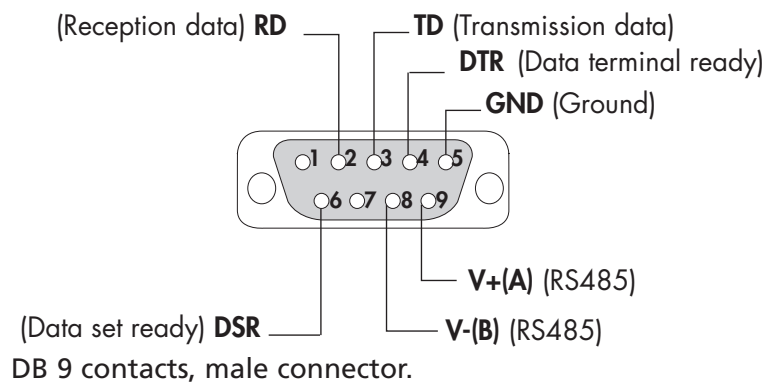

Examples of possible connection RS 232 with a single controller



Serial link RS 485

Parallel type connection: communication will be lost only on the disconnected pump.

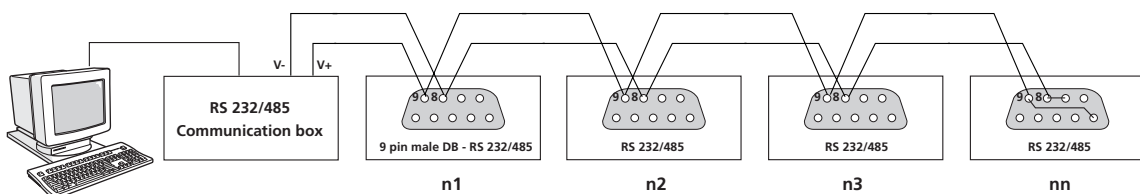

End of the line wiring:

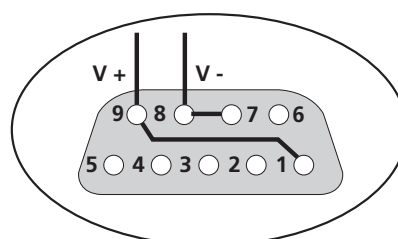



Operation

Operating instructions MAGPOWER Controller Detailed contents

C 100 *Safety Instructions for product use*

C 200 *Controller start-up*

- The parameter setting keys
- Configure the parameters for the application using the various menus

C 300 *Controlling the pump using the controller front panel*

- Serial link setting

C 400 *Controlling the pump using the controller front panel*

C 450 *Local or remote mode operation*

- Local mode operation
- Pumping start
- Pumping stop
- Remote mode operation

C 500 *«External safety» contact operation*

C 600 *“INH” Inhibit mode operation*

- «INH» mode disable
- «INH» mode valid

C 700 *Standby mode operation “without braking” or “with braking”*

- Without braking
- With braking

C 800 *Detailed description of RS232 and RS485 commands*

Safety instructions for product use

WARNING

Before using pump and controller, make sure that the mechanical and electrical connections have been made according to the safety recommendations: refer to chapter B from pump operating instructions and to associated controller operating instruction manual.

CAUTION

It is highly recommended to use:

- an inlet screen at the pump inlet;
- an isolation valve between the chamber to be pumped and the pump;
- an isolation valve between the pump and the roughing pump.

WARNING

■ Do not operate the pump until it is securely fixed. If the pump seizes, the stored energy of the rotor may cause further damage and injury to people. ( B300).



■ Risk of cut

The access to the rotor of a turbomolecular pump with an unconnected inlet port is dangerous. In the meantime, if the pump is not switched on, it may be driven by another pump in operation.

Always connect the pump inlet port before starting the pump.



■ Specific operating conditions may exist that require extra caution from users due to the high temperatures generated (outer surfaces > 70° C): wear protective gloves and leave the pump to cool before working on the product. .

■ Pump damage

Make sure that exhaust pipe line and pump internal parts are not clogged by process by-products (e.g. condensable products ...). If exhaust line is not clear, contact the customer service.

■ As loss of cooling water creates a significant risk for the pump, regularly check the right operation of the cooling circuit.

DANGER

■ Risk of injury by cutting.

The inlet of the pump musn't be disconnected as long as the rotor is moving and without having disconnecting the power line cable.

WARNING

Risk of electrical shock.

The turbopump and the controller must only be disconnected from each other when the turbopump is completely at rest and the controller disconnected from the power supply.

Never unplug the pump by disconnecting the main cable. Only the authorized and trained technicians can perform intervention on the product.

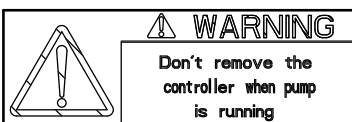

Located on the controller, this label indicates that the controller musn't be disconnected when the pump is running.



Safety instructions for product use

WARNING

Standard precautions before any maintenance operations:

Before performing a maintenance operation, stop the pump. When the pump is at rest, switch off the pump by setting the controller main switch to «0», wait 5 minutes before disconnecting the main cable. If this last one remains connected, some components will still be energized.

Be sure that the controller status is visible from the operator otherwise disconnect the cable from the pump.

Refer to the controller Operating instructions to control and monitor the pump ( chapter C). Refer to the controller Operating instructions if a fault appears ( D 200).

Controller start-up

Once the various electrical connections have been made, set the main switch on the rear panel to "I".

The controller performs a self-test and identifies the pumps to which it is connected.

The initialization time is approximately 15 seconds.

Display initialization:

The equipment is identified, the program version is displayed.

Indicator lights test:

they are lit in succession.

The working screen is displayed (connected pump identification).

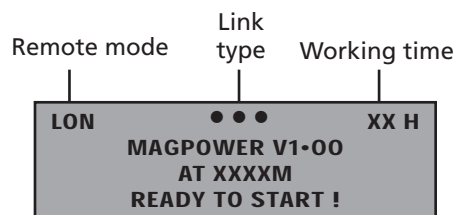
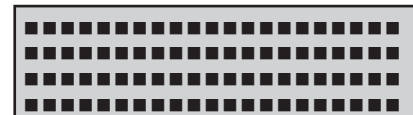

The parameter setting keys

Parameter setting access



- used to access the parameter setting mode.
- used to exit the various menus without validating the functions.

Selection



- used to move between menus, or from one parameter to another.



- used to select or adjust the value of the selected parameter.

Validation



- used to validate the selection of a menu, parameter or value.



- used to exit the menus and return to the pump parameter display.

Controller start-up

The parameter setting keys (Cont.)

The messages on the display are:

- during acceleration, until the nominal speed: "STARTING" and the green light is OFF.
- pump at nominal speed and pump not at chosen temperature: "WAITING HEAT" and green light is ON.
- pump at nominal speed and at temperature ($\pm 3^{\circ}\text{C}$): "OK FOR PROCESS", and the green light is ON.

Configure the parameters for the application using the various menus

Enter the sub-menus by pressing:

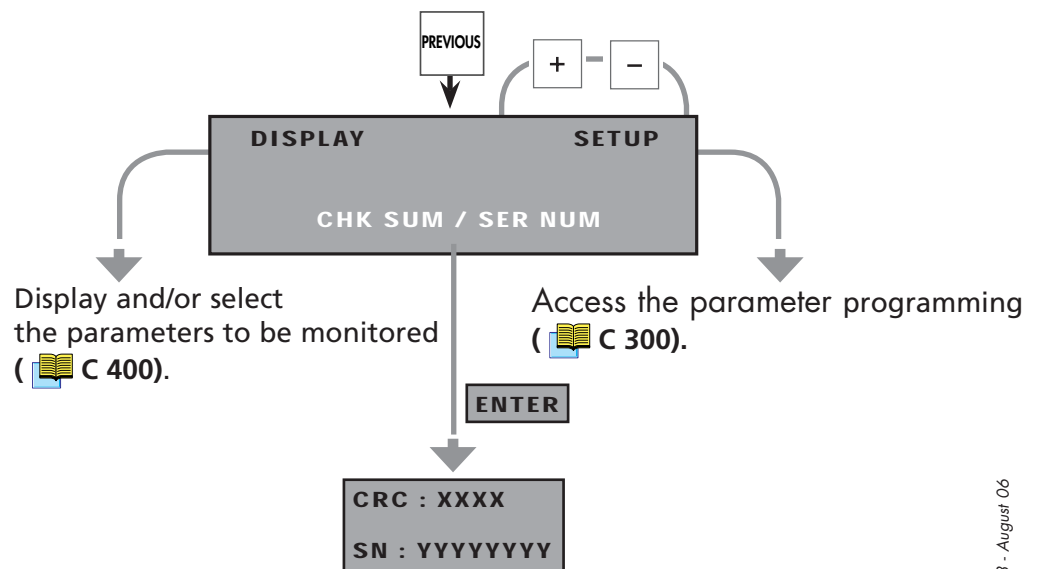

MAGPOWER controller settings

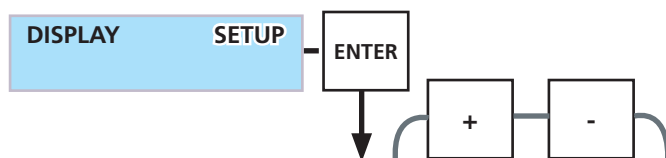

Menu	Sub menu	Description	Limit	Factory configuration
ACCESS CODE		Enter the access code	0 to 65535	0
REMOTE CONTROL		Mode Remote	KEYBOARD REMOTE HARD SERIAL LINK LON	LON
SET ANALOG OUT		Configurer la sortie 0 - 10 V	Speed: 10 V = 60000 tr/mn ( B 431) I motor : 0A (0V) 15A (10V) 1.5 A per 1V PUMP : 0,1V per 1 °C CONT : 0,1V per 1 °C	Speed
STANDBY SPEED		Modify the STANDBY speed	15000 to nominal speed*	15000
STANDBY MODE		Modify the STANDBY speed	With / without braking	without braking
BUZZER		Activate or deactivate the buzzer	ON or OFF	OFF
TEMPERATURE UNIT		Select the temperature measurement units	°C or °F	°C
THERMOSTAT		Modify the heating temperature	OFF or ON (31 à 75 °C)	65 °C
RELAY AT SPEED		Modify the speed contact threshold	-3% to -50%	-3%
LONWORKS		LONWORKS parameters	NODE SUBNET	66 2
SET SERIAL LINK		Set the serial link parameters	RS232/RS485/NETWORK (see sub-menus folios 2 et 3)	RS232
SET START DELAY		Modify the time before starting up the pump	00 mn 00 s to 240 mn 59 s	00 mn 00 s
TIME TO VENTING		Modify the time before opening the venting valv	De 00 mn 00 s to 59 mn 59 s	00 mn 01 s
VENTING TIME		Modify the venting valve opening time	De 00 mn 00 s to 59 mn 59 s	00 mn 01 s
BEARINGS (LIMITS)		Modify the bearing alert threshold	0 to 100%	20%
BEARINGS		Modify the bearing counter after pump/controller/bearing replacement	0 to 100 %	100%
PUMP TIME		Pump running time	0 to 65500 h	0 h
NEW CODING		Modify the access code	0 to 65535	0

* See operating instructions of the pump

MAGPOWER controller settings

Serial link setting

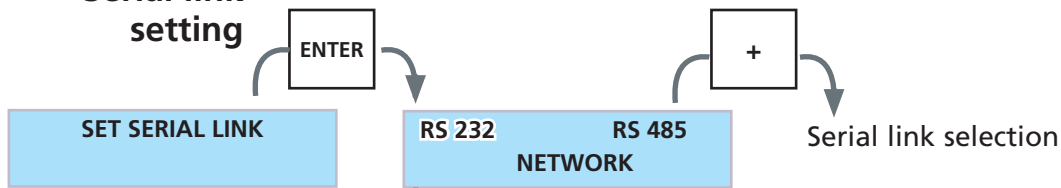

Menu	Sub menu	Description	Limit	Factory Configuration
RS232	Speed (bauds)	Transmission speed	4800-9600-19200-38400-57600	9600
	Parity	Parity	None Even Odd	None
	Data bits	Data length	7 or 8	8
	Stop bits	Number of STOP bits	1 or 2	1
	Echo	Authorizes or does not authorize the echo of characters received on the link	On or OFF	ON
	Separator	Data separating	0 to 255	44 (virgule)
	Address	Number of controller in a multiple link	0 to 255 ON or OFF	0 OFF
	Set data logger	Authorizes transmission at pre-set intervals on the serial link, if ON Set the transmission interval	1 s to 4mn 15 s ou 255 s	00 mn 01 s

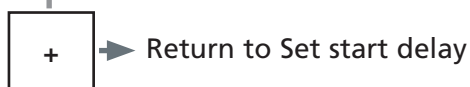

RS232 RS 485 NETWORK

```

    graph TD
      A["+"] --> B[RS232 RS 485 NETWORK]
  
```

Menu	Sub menu	Description	Limit	Factory Configuration
RS485	Speed (bauds)	Transmission speed	4800-9600-19200-38400-57600	9600
	Parity	Parity	None Even Odd	None
	Data bits	Data length	7 or 8	8
	Stop bits	Number of STOP bits	1 or 2	1
	Separator	Data separating character	0 to 255	44 (coma)
	Address	Number of controller in a multiple link	0 to 255	0

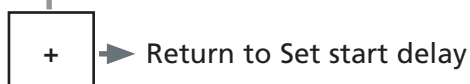

MAGPOWER controller settings

Serial link setting (continued)

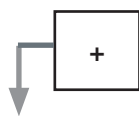
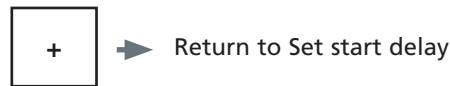

Menu	Sous-menu	Description	Limites	Factory Configuration
NETWORK	Address	Number of controller in a sequence in the case of the multiple link	0 to 255	0

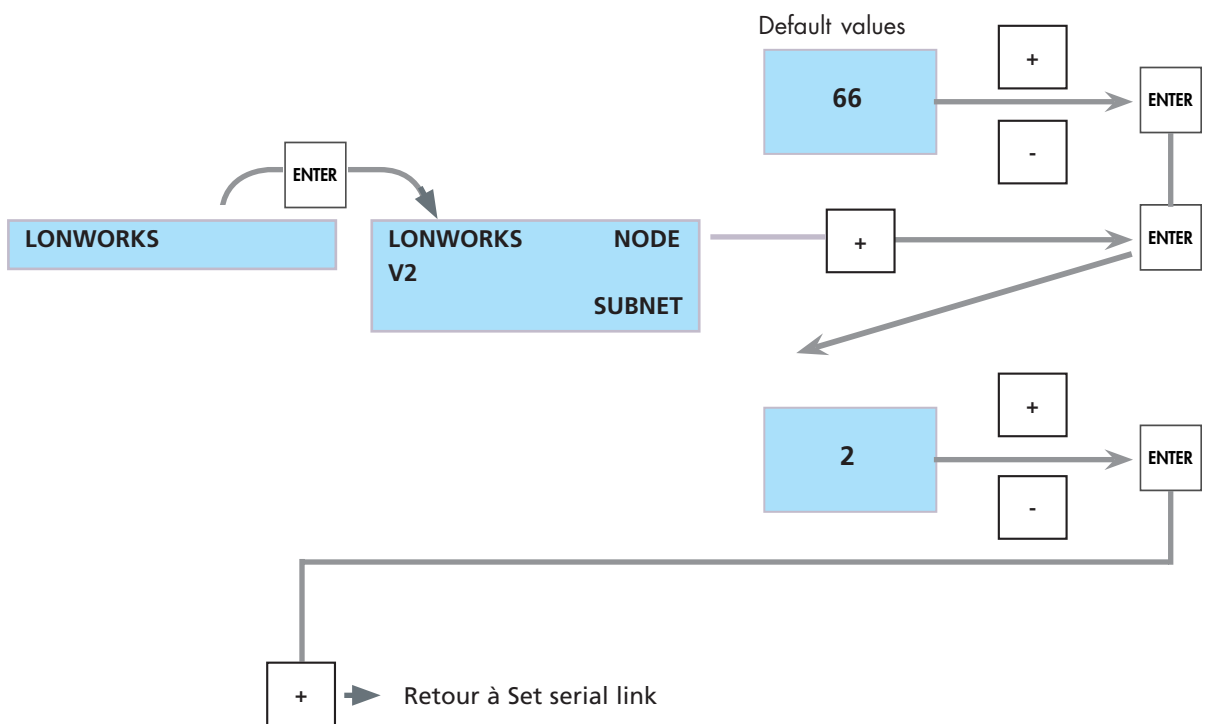
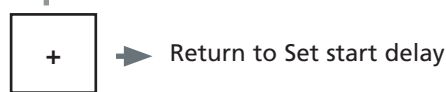

Controlling the pump using the controller front panel

The controller must be on the «Keyboard» mode ( C 300).

Rotation indicator lights:

Yellow lit

The pump rotational speed is **lower** than the selected speed.

Red lit

The pump is faulty. This fault is accompanied by an audible signal. Red flashing when an alert appears.

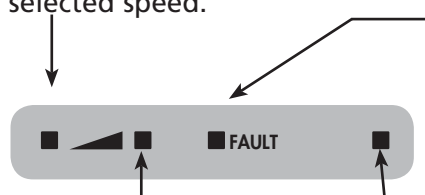

Yellow lit

Standby mode selected.

Green flashing

The pump rotational speed is **higher** than the selected speed (decrease of the selected speed during operation).

Green lit

The pump has reached the selected speed.

Start up the pump by pressing 

The pump accelerates to the nominal speed. The pump is started up to reach the selected speed.



The yellow rising speed indicator light comes on. When the pump reaches its selected speed, the yellow indicator light goes off and the green indicator light comes on.

Select the reduce speed mode by pressing 

The speed indicator light comes on. The pump regulates its speed to reach the pre-defined value ( C 300).



Stop the pump by pressing 

The rotation speed monitoring indicator light goes off. The pump motor is no longer powered, the pump decelerates.

Controlling the pump using the controller front panel

Display the pump and controller data

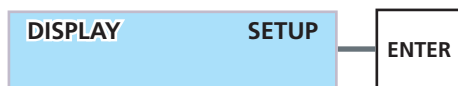

Pump and controller status

- pump temperature
- pump motor current
- controller temperature
- pump rotational speed

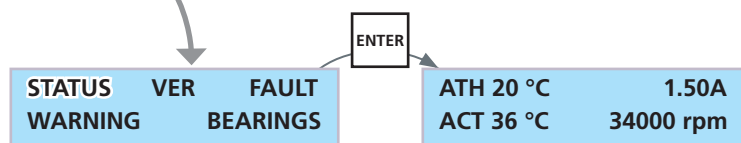

Controller versions

- Ve - Vv - Vm

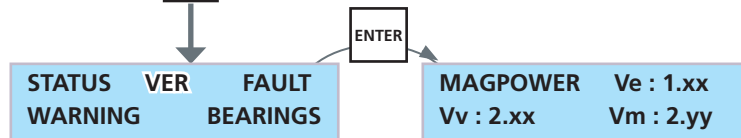

Display of last 10 faults

- number of hours of pump operation when the fault appeared
- record number (1 to 10)
- fault title

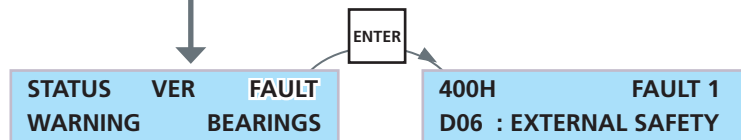

Display of last 10 warnings

- number of hours of pump operation when the alert appeared
- record number (1 to 10)
- alert title

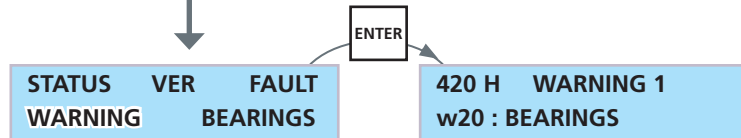

Bearings data

- the bearing life time (%) and the alert threshold (%)

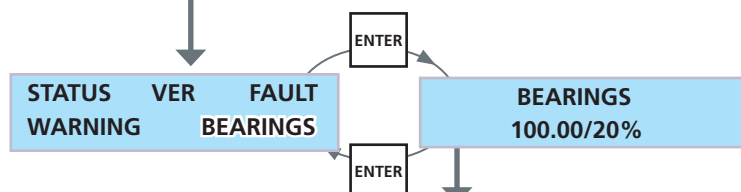

The bearing life time (% remaining)

Local or remote mode operation

Pumping cycle from chamber at atmospheric pressure

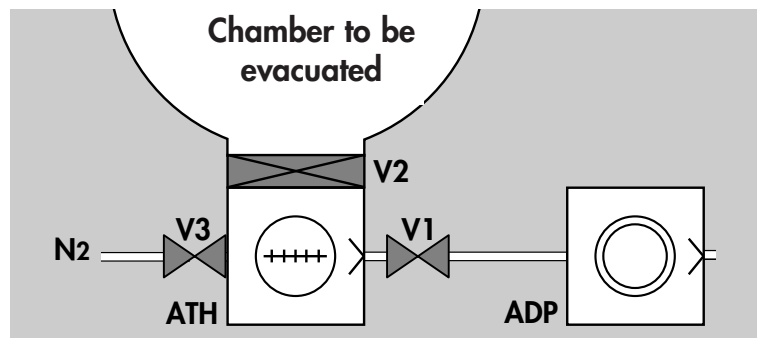

Local mode operation

CAUTION

In the case of a local mode operation of the controller, make sure that the terminal plug (delivered with the controller) is connected to the remote control connector at the rear of the unit (B 430 for the wiring of the plug).

The controller screen displays "KEYB".

```
KEYB          XX H
MAGPOWER VX.YY
ATX xxxxxx
READY TO START!
```

Pumping start

Switch on the controller

The valve **V3** is closed and the «FAULT» contact closes.
The rotor is levitated.
The heating band is powered (MT models).

Start the pumping by



The roughing pump starts and valve **V1** opens (if the roughing pumping is controlled by the controller).

If the pump start-up time has been programmed

(C 200), the countdown of the time before the pump begins rotating is displayed on the screen.

If the pump start-up time has not been programmed, the roughing pumping system and the pump start up at the same time.

Open the valve V2

Take care to wire the customer relay in series with «ISOL. VALVE» contact (for a gauge for example).

The chamber continues to be pumped until the customer operating pressure is reached.

Select the stand-by mode



The pump reaches the standby speed programmed

(C 300). The standby mode can be selected when pump is stopped or in rotation.

Local or remote mode operation

Pumping stop

Stop the pumping by



(no air inlet valve connected)

This closes the roughing isolation valve V1 and the roughing pump stops. If the ISV contact is connected, V2 closes.

The braking of the pump from maximum speed to 10000 rpm takes $t < 10$ min. The controller display indicates temporarily:



Open the valve V3

1st case

No air inlet valve connected

(standard configuration from the manufacturer)

The time for the delay to open and opening time are 0s.

After a STOP signal (or a fault), the pump will brake without air-inlet. The duration of the rotor slow down until its complete stop could be more than 30 minutes.

No message of venting on the front panel.

2nd case:

Air inlet valve connected

The customer has to set the delay to open the valve and the time of opening (C 300 "Time to venting" and "Venting time").

After a STOP signal (or a fault), the pump will brake without air-inlet down to 10000 rpm. At 10000 rpm plus the delay (C 300), the air inlet valve will open. It stays open for the chosen opening time (max. 3599s).

When the valve is open, there is a message «VENTING» on the front panel, during the venting time.



Close the valve V3

It closes before if the rotation of the pump reaches 0 rpm or if there is a **START** signal. If the set opening time is reached before the pump reaches 0 rpm, the controller displays:

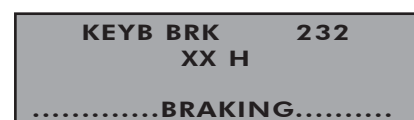

Close the valve V2

The level of vacuum in the chamber is maintained.

Local or remote mode operation

Immediate restarts If the pump has been stopped by an air inlet, we advise to limit to 2 the number of immediate restarts per hour.
If the pump has been stopped without air inlet, immediate restarts are not limited.

Event of a power cut If a power cut occurs, the rotor remains suspended by the energy emitted by the motor's counter-electromotive force, until the rotor rotation speed is low enough (around 7000 rpm) so that it can land on the back-up bearings without being damaged.

Short power cuts If the power is restored before the minimum speed is reached, the pump recovers its initial speed without any disturbance. The bearing life counter doesn't decrease.

Otherwise, the minimum speed is reached before the power is restored:

- «ISOL.VALVE» contact is open (V2 closes);
- «START» contact is open (V1 closes);
- the air inlet valve is open if set;
- the pump lands on its back-up bearings;
- the controller is stopped;
- the landing's time counter decreases ( **D 100**).

The normal start-up procedure is to be resumed after power has been restored ( **page 1**).

If the pump is remote controlled:

- disable "Remote Start";
- valid "Remote Stop";
- valid again "Remote Start" ( **B 430**).

Local or remote mode operation

Remote mode operation

Select your remote mode following the list.

In the case of Remote mode operation, the «Remote control» connector has to be wired according to the remote functions requested (📖 B 430). Set the controller on "Remote ON" mode (📖 C 300).

The START/STOP/STANDBY commands are the same as those for the local mode.

KEYBOARD

KEY	XXX	XX H
-----	-----	------

HARD

REM	XXX	XX H
-----	-----	------

LINK

REM	XXX	XX H
-----	-----	------

LON

LON	• • •	XX H
-----	-------	------

XXX = 232 or 485 or NET

«External safety» contact operation

This operation mode is always operational even on "Local" or "Remote" mode.

If the «EXT. SAFETY» contact on the «Inputs/Outputs» connector ( B 430) is open:

- the controller display

D 06 : EXT.SAFETY

indicates:

- the pump is stopped and the air inlet valve opens if the air inlet valve parameter is set.

To restart the pump, close the «EXT. SAFETY» contact and start the pump:

- in local mode: push the START key;

- in remote control mode: open «START» contact then, close it

( B 430).

«INH» Inhibit mode operation

This operation mode is always operational even on "Local" or "Remote" mode.

"INH" mode disable

The controller screen displays "INH. BRK."



```
INH. BRK.                XX H
.....BRAKING.....
```

The controller doesn't supply the motor, inhibit the progressed functions and memorize them. There is no air inlet except if the venting time is on progress.

The actions on START, STOP (KEY or REM) are deactivated.

"INH" mode valid

The controller screen displays "KEY" or "REM".



```
REM                      XX H
.....STARTING.....
```

The controller powers the motor and restores the previous memorized operating status.

Standby mode operation “without braking” or “with braking”

The “without braking” standby mode does not modify the controller operation.

The Standby mode must be activated.

The “with braking” standby mode modifies the management of the outputs “At speed”, “At speed and thermostatic temperature” and the time of braking ( **B 430**) when the pump must slow to reach its Standby speed.

“Without braking”

Factory configuration

The two contacts “At speed” and “At speed and thermostatic temperature” aren’t opened during the braking of the pump toward its Standby speed.

There is no electrical braking.

“With braking”

The two contacts “At speed” and “At speed and thermostatic temperature” open during the braking of the pump and close up when the speed reaches the value of Standby speed programmed by the controller.

The slowing down is the same than a “Stop” order reception.

Detailed description of RS232 and RS485 commands

(valid from V1.XX version variable drives)

Conventions applicable to the syntax of all commands

adr = adresse, de 000 à 255
<CR> Carriage Return (ascii 13)
<LF> Line Feed (ascii 10); entre crochets : sa présence n'est pas obligatoire.

Status values

OK : commande exécutée normalement

Error messages

Err0 : erreur de réglage (hors limite)
Err1 : erreur d'ordre (syntaxe)
Err2 : erreur de paramètre (ex : car non hexa)
Err3 : erreur de contexte
Err4 : erreur de checksum

ADR Specifies the address of the device for networking.

Syntaxe

#adrADR aaa<CR>[<LF>]
adr = address of the device before the command
aaa = new address of the device
condition : $000 \leq aaa \leq 255$

Result

#aaa,OK or Err2
This command is used to allocate a specific number to each of the products making up a network (loop for RS 232 or parallel for RS 485).

it is important to note down the number allocated to each device.

CHKVS or CHKXT Returns the checksum of the program (VS or X)

Syntax

#adrCHKVS<CR>[<LF>]
#adrCHKXT<CR>[<LF>]

Result

#adr,xxxx <CR>
_____ in hexadecimal characters

Detailed description of RS232 and RS485 commands

DEF List of the faults

Syntax #adrDEF<CR>
List of the faults separated by the separator character.

Result #adr,OK if there no fault

DLI Define the Datalogger transmission interval (only with RS232)

Syntax #adrDLIxxx<CR>[LF]
xxx : Datalogger send interval in seconds
condition $001 \leq xxx \leq 255$

Result #adr,ok or Err2
See also : DLR If ok, the interval sent is stored in user memory.

DLR Enables Datalogger operation (only with RS232)

Syntax #adrDLR<CR>[<LF>]

See also: DLI, STA, SEP The main characteristics of the pump and its controller (see also **STA** command) are sent over the RS link, at the rate defined by the **DLI** command.

Note: any new characters arriving on the serial port (RS232) will cancel the automatic DataLogger transmission.

ECH Enables or disables command echoing

Syntax #adrECHON<CR>[<LF>]
enables all characters received to be echoed over the serial port (RS 232 only)
or
#adrECHOFF<CR>[<LF>]
disables all characters received from being echoed over the serial port

Result #adr,ok

Comments:

- This command is disabled in RS 485 operation, the value OFF is required.
- Using a loop-type RS 232 network requires «ECHON» operation.

Detailed description of RS232 and RS485 commands

IDN Identifies the device which is communicating, and its software version

Syntax #adrIDN<CR>[<LF>]

Result #adr, MAG POWER - Vx.zz' <CR>

Retourne le type de Superviseur (VS), la version de logiciel (x), son édition (zz).

IDP Identifies the product and the name of the pump number

Syntax #adrIDP<CR>[<LF>]

Result #adr, MAGPOWER - Vx.zz' ATH xxx <CR>

LEV10 Retourne l'état des paramètres définis par SET

Syntax #adrLEV10<CR>[<LF>]

Result #adr,nnnnn,sssss,00000,0,cccc,eeee,dddd,pppp,qqqq,jj,kk,III,mm
m

#adr,nnnnn,sssss,00000,0,cccc,eeee,dddd,pppp,qqqq,jj,kk,III,mm
m

Return current values:

nnnnn : nominal speed set point (in rpm)

sssss : stand-by speed set point (in rpm)

00000 : not used

0 : not used

cccc : pump working time (in hours)

eeee : electronic working time (in hours)

dddd : start delay (max 14459 s,
that is 240 mn 59 s)

pppp : time to venting (max 3599 s, that is 59 mn 59 s)

qqqq : venting time (max 3599 s, that is 59 mn 59 s)

jj : speed threshold for relay (3 to 50%)

kk : control temperature (30 to 75°C)

III : bearing threshold (0 to 100%)

mmm : bearing current value (0 to 100%)

Detailed description of RS232 and RS485 commands

NSP Switches the speed set point to the nominal speed value

Syntax #adrNSP<CR>[<LF>]

Result #adr,OK

The speed set point for the pump is set to its nominal value.

OPT Used to select possible user choices

Syntax #adrOPT01,n<CR>[<LF>]
choice of parameters on the analog output:
n = 0 : real pump speed
n = 1 : pump current
n = 2 : temperature of pump body
n = 3 : temperature of internal electronics

#adrOPT02,n<CR>[<LF>]
choice of temperature unit
n = 0 : degrees Centigrade
n = 1 : degrees Fahrenheit

#adrOPT11,n<CR>[<LF>]
buzzer
n = 0 : without
n = 1 : with

#adrOPT14,n<CR>[<LF>]
command mode
n = 0 : front panel n = 1 : Remote
n = 2 : RS n = 3 : LON

#adrOPT25,n<CR>[<LF>]
braking
n = 0 : braking of 31000 tr/mn to 10000 tr/mn
n = 2 : braking of 31000 tr/mn to 0 tr/mn

Result #adr,OK

The choice of the temperature unit affects the results of the **DLR** and **STA** strings and the display (if cabinet fitted).

RPM Defines the speed set point in stand-by value

Syntax #adrRPM, nnnnn<CR>[LF]

Result #adr,OK or
#adr,ErrX

1, out of range ; 2, parameters
3, context (not in stand by model)

Detailed description of RS232 and RS485 commands

SBY Switches the speed set point to the stand-by value

Syntax #adrSBY<CR>[LF]

Result #adr,OK

Resets the stand-by speed to its Standby stored value, and allows it to be modified if an «RPM» command is sent.
This configuration is automatically stored in user memory.

SEL 10 Returns the state of the parameters defined by OPT

Syntax #adrSEL10<CR>[<LF>]

Result #adr,a,u,1,b,r

a: Returns choice parameters on the analog output
a=0: real pump speed
a=1: pump current
a=2: temperature of pump body
a=3: temperature of internal electronics

u: Returns the choice of temperature unit
u=0: degrees Centigrade
u=1: degrees Fahrenheit

1: Not used

b: Returns buzzer choice
b=0: without
b=1: with

r: Returns remote choice
r=0: remote mode off
r=1: remote mode on

Result #adr,OK

Detailed description of RS232 and RS485 commands

SET Defines the internal operating parameters

Syntax

#adrSET10,cccc<CR>[<LF>]: pump working time (in hours)
 #adrSET11,eeee<CR>[<LF>]: electronic working time (in hours)
 #adrSET13,dddd<CR>[<LF>]: start relay
 (max 14459 s, that is 240 mn 59 s)
 #adrSET14,pppp<CR>[<LF>]: time to venting
 (max 3559 s, that is 59 mn 59 s)
 #adrSET15,qqqq<CR>[<LF>]: venting time
 (max 3559 s, that is 59 mn 59 s)
 #adrSET30,jj<CR>[<LF>]: speed threshold (3 to 50%)
 #adrSET31,kk<CR>[<LF>]: control temperature (30 to 75°C)
 #adrSET31,30<CR>[<LF>]: stop the pump thermostage
 #adrSET32,lll<CR>[<LF>]: bearing threshold (0 to 100%)

Result #adr,OK or ErrX

SPD Returns the current speed

Syntax #adrSPD<CR>[<LF>]

Result #adr,nnnnn rpm

STA Returns the status of the internal dynamic parameters

Syntax #adrSTA<CR> or STA<CR>

Result #adr,sss, rrrrr, vv, www, xxx, yyy, zzz, aa, bbbbb, ccc, ddd, gggggggggggg
 gggggggggggg<CR>

adr: adress

s1: order status

BIT	7	6	5	4	3	2	1	0
		INH	KEY	STOP	serial link	REM	STDBY	START
0		OFF	OFF	OK	OFF	OFF	OFF	OFF
1	1	ON	ON	fault	ON	ON	ON	ON

Detailed description of RS232 and RS485 commands

STA Returns the status of the internal dynamic parameters (Ctd.)

s2: pump status

BIT	7	6	5	4	3	2	1	0
		Fault	Warning temp.	Braking	Nom.speed and Temp	Accelerating	Start	Power
0		OK	OK	OFF	OFF	OFF	OFF	OFF
1	1	fault	warn.T	ON	ON	ON	ON	ON

s3: valves status

BIT	7	6	5	4	3	2	1	0
		At speed	(free)	(free)	Water valve (NO)	Thermostat	Air inlet (NF)	Isol.valve (NF)
0		OFF			close	OFF	close	close
1	1	ON			open	ON	open	open

- | | |
|---------------------|----------------------------|
| rrrrr: speed in rpm | zzz: Axial Z |
| vvv: Radial Xh | aa: Motor voltage V |
| www: Radial Yh | bbbb: Motor current mA |
| xxx: Radial Xb | ccc: Pump temp (° C) |
| yyy: Radial Yb | ddd: Controller temp (° C) |

g	0 = OK	1 = ALERT	2 = FAULT
0			D00: seized pump
1			
2		W02: mot.ovrheat	
3			
4			
5			D05: over-current
6			D06: ext. safety
7			D11: mag. suspens.
8			
9			
10			D14: yh
11			D15: xh
12			D16: yb
13			D17: xb
14		W19: bearing	D18: Z
15		W21: act temp.	D20: bear. changed
16		W23: pump temp	D22: act temp.
17			D24: pump temp.
18			D25: temp. sensor
19			D26: no connect
20			
21			
22			
23			
24			D35: DPRAM MAG

Detailed description of RS232 and RS485 commands

TMP Defines the operating state of the turbomolecular pump

Syntax #adrTMPON<CR>[<LF>] : start pump rotation
#adrTMPOFF<CR>[<LF>] : stop pump

Result #adr,OK ou #adr,Err3 if the pump is already in the state requested
(context error)

VER Defines the version of electronics «extension» + «frequency converter» + «magnetic bearing » + «LONWORKS»

Syntax #adrVER<CR>[<LF>]

Result #adr,Ve: 1.00, Vv: 1.02, VI: 2.01, Vm: 0.00
(extension) (freq. conv.) (Lon) (magnet)

if not LONWORK : VI:0.00



Maintenance

Operating instructions MAGPOWER Controller Detailed contents

D 100

Safety instructions for product removal

D 150

Maintenance frequency

D 200

Diagnosis and Troubleshooting

- Fault type
- When a defect appears
- Faults identification
- Several defects appear
- Fault is not indicated by the controller

Safety instructions for product removal

WARNING

- Maintenance must be performed by a skilled maintenance operator trained in the relevant health and safety aspects (EMC, electrical hazards, chemical pollution, etc.).

Isolate the product from all energy sources (mains electricity, compressed air, water, gas ...) before starting work.

- Standard precautions before any maintenance operation:

Before performing a maintenance operation, stop the pump. When the pump is at rest, switch off the pump by setting the controller main switch to «0», wait 5 minutes before disconnecting the main cable. If this last one remains connected, some components will still be energized.

Be sure that the controller status is visible from the operator otherwise disconnect the cable from the pump.

- Risk of injury by cutting:

The inlet of the pump mustn't be disconnected as long as the rotor is moving and without having disconnected the power line cable.

- After pumping on corrosive or toxic gases, it is strongly recommended to seal the pump with blanking plates in case of return to the repair service centers ( E 100). Don't forget to label in a visible way the product for the operator.

DANGER

- Risk due to pumping conditions:

Remaining process gases in the pump may cause severe injury or death. Before removing the pump from the installation, continue N2 flow from the process tool for 30 min. Nitrogen pressure and flow rate should be identical to the programmed values during process.

- Chemical supplies coming from the tool, as well as the water and the nitrogen need also to be locked out / tagged out.

- During pump removal, operator could be in contact with process residues on the inlet and exhaust ports which could cause severe injury or death. Ask your safety department for instructions according to the local regulations.

Safety instructions for product removal

Users are advised:



Wear gloves, protective glasses, any appropriated safety equipment.
Ventilate the premises well.

Do not eliminate maintenance waste via standard disposal channels. Have it destroyed by a qualified company if necessary.
Install the inlet and exhaust blanking plates, thus delivered with the pump or available as accessories ( E100) .

The outside of the product and control box can be cleaned with a lint free wiper. Avoid using cleaning products that deteriorate printed surfaces and self adhesive labels. All other cleaning operations must be done by our service centers.

Decontamination – product dismantling

According to the regulations 2002/96/CE about Waste of electrical and electronical equipments, and 2002/95/CE about Restriction of Hazardous substances, the manufacturer provides a recycling paid service for the end-of-life of waste electrical and electronic equipment.

Any obligation of the manufacturer to take back such equipment shall apply only to complete not amended or modified equipment, using adixen Vacuum Products original spare parts, delivered by adixen Vacuum Products, containing i.e. all its components and sub-assemblies.

This obligation will not cover the shipping cost to an adixen Vacuum Products service center.

Before returning the product, fill in the safety form, attach it to the product before shipping to the service-repair office closest to you.

How to contact us

The overhaul must be performed by manufacturer's trained personnel. Contact nearest service center or the service support at the following e-mail address: support.service@adixen.fr

Maintenance frequency

Back-up ball bearings

When the pump is running, the rotor is levitated magnetically. There is therefore no friction between moving and fixed parts.

When the pump is stopped by the controller, the back-up ball bearings are not used. The rotor remains levitated by magnetic ball bearings.

Only the back-up ball bearings require maintenance: they are designed to withstand many accidental shut-downs, or many landings of the rotor on the ball bearings at full speed.

These accidental shut-downs occur only in exceptional circumstances: broken power supply cable, strong shocks, faulty electronics. It is advisable to check the bearing counter and provide ball bearing maintenance, when needed.

The bearing counter

Back-up ball bearings are designed to withstand abnormal landings at full speed.

The wear of the back-up ball bearings is internally monitored by the controller, based on the rotation speed and the landing duration.

Initial percentage value is set at 100%. When this percentage reaches 0%, an alarm is generated, pump can't restart, and back-up ball bearings need to be replaced by authorised Service Center.

Warning messages for pumps maintenance

The ball bearing alert threshold can be set on the menu ( C300).

The internal memory of the controller also informs the operator when the ball-bearings require maintenance ( D200).

CAUTION

The life time of the rotor is at least 5 years under normal conditions with clean process. Please contact the Service Center to check your application.

The full overhaul must be performed by manufacturer's trained personnel.



Only controller replacement, inlet screen or pump valve replacement are authorized at the customer's site.

Contact the nearest service center or the service support at the following e-mail address: support.service@adixen.fr

Diagnosis and troubleshooting

- Fault type**
- The screen is locked on a displaysee page 1
 - The fault is indicated by the controllersee page 2
 - The fault is not indicated by the controllersee page 6

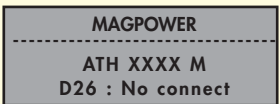
The screen is blocked

Incident	Cause	Consequence	Remedy
	When the controller is started up, the pump cannot be identified.	The controller is disabled.	<ul style="list-style-type: none"> • Check that the cable linking the pump to the controller is correctly connected. • Otherwise ① Contact the Customer Service
	Converter power supply problem.	The controller is disabled.	<ul style="list-style-type: none"> • ① Contact the Customer Service
	The micro board is not working.	The controller is not working.	<ul style="list-style-type: none"> • ① Contact the Customer Service

Diagnosis and troubleshooting

When a defect appears

The «FAULT» contact opens ( B 430).

Depending on the defect type:

- The «FAULT» signal can be on, for an alarm, and flashing for an alert;
- the air inlet valve must be open (option);
- and the controller can stop the pump.

To start the pump after a default, the cause must be corrected, then switch power off and on to start the correct operation.

In the following table, we'll use the symbol:

Faults identification

<input type="checkbox"/> Fault	<input checked="" type="checkbox"/> The signal lights on <input type="checkbox"/> The signal lights not on <input checked="" type="checkbox"/> The signal light is flashing
 OPEN	Y The air inlet valve opens N The air inlet valve doesn't open

Incident	Cause	FAULT <input type="checkbox"/>	OPEN 	Consequence	Remedy
D 00: SEIZED PUMP	Pumping cell seized.	<input checked="" type="checkbox"/>	N	The controller does not supply the motor.	<ul style="list-style-type: none"> • Check manually that the rotor rotates, otherwise ① Contacter le Service clients.
W 02: MOTOR OVERHEAT	The stator motor temperature is too high.	<input checked="" type="checkbox"/>	N	The controller temporarily stops driving the pump rotation until the temperature drops back below the authorized limit.	<ul style="list-style-type: none"> • Reduce the number of start-ups per hour. • Reduce the working pressure or the flowrate. • For thermostatic pump, check that the water valve is opening. • Check the water cooling of the pump (check that the water is present and the flowrate). • Check the purge flowrate.
D 05: OVER-CURRENT	Motor over current or Hall sensor fault.	<input checked="" type="checkbox"/>	Y	The controller stops the motor and air inlet valve is activated if it is connected.	<ul style="list-style-type: none"> • Reduce the flowrate. • Switch off the controller and restart it • Check the cable link. • Try to start the pump: Manual mode: pressing «start». • Remote mode: open and close the «start» contact. • If the fault happens again ① Contact Customer Service

Diagnosis and troubleshooting

Incident	Cause	FAULT		Consequence	Remedy
		<input type="checkbox"/>	<input checked="" type="checkbox"/>		
D 06: EXTERNAL SAFETY	The external safety contact on the connector is activated.	<input checked="" type="checkbox"/>	<input checked="" type="checkbox"/>	The controller stops the motor, «START» contact and «ISV» contact open. The air inlet valve is activated if it is connected. The pumps can not restart.	<ul style="list-style-type: none"> • Test the external safety devices and repair the fault ( B 430). • Try to start the pump: Manual mode: pressing «start», Remote mode: open and close the «start» contact.
D 11: MAG SUSPENSION	Mechanical or electrical problem.	<input checked="" type="checkbox"/>	<input checked="" type="checkbox"/>	No magnetic levitation. The pump can not start.	<ul style="list-style-type: none"> • Check that the rotor is free when rotating. • ① Contact the Customer Service
D 14: Yh D 15: Xh D 16: Yb D 17: Xb D 18: Z	The rotor position outside authorized limits.	<input checked="" type="checkbox"/>	<input checked="" type="checkbox"/>	The controller stops the motor. «START» contact and «ISV» contact open. The air inlet valve is activated if it is connected. The pump can not restart.	<ul style="list-style-type: none"> • Check that there are no vibrations on the pump frame. • Check that the attachments are correctly fastened. • If the message disappears, try to start the pump. • If the fault happens again, ① Contact the Customer Service
W 19: BEARING	The bearing life time is smaller than the alert threshold.	<input checked="" type="checkbox"/>	<input type="checkbox"/>	Another landing on the bearing is possible.	<ul style="list-style-type: none"> • ① Contact the Customer Service to replace the ball bearings.
W 21: MAG TEMP.	The controller temperature exceeds the authorized limit 75° C.	<input checked="" type="checkbox"/>	<input type="checkbox"/>	The controller does not stop the motor.	<ul style="list-style-type: none"> • Check that the ventilation is operating (air admission not blocked). • Provide more space around the controller.
W 23: PUMP TEMP.	The pump temperature exceeds the authorized limit 80° C.	<input checked="" type="checkbox"/>	<input type="checkbox"/>	The controller does not stop the motor.	<ul style="list-style-type: none"> • Check that the pump cooling device is running.
D 20: BEARINGS MUST BE CHANGED	The authorized limit for the number of landings on the emergency bearings has been reached.	<input checked="" type="checkbox"/>	<input checked="" type="checkbox"/>	The pump can not restart.	<ul style="list-style-type: none"> • ① Contact the Customer Service to change the emergency bearings.

Diagnosis and troubleshooting

Incident	Cause	FAULT	OPEN	Consequence	Remedy
		<input type="checkbox"/>	<input checked="" type="checkbox"/>		
D 22: MAG Temp.	The controller temperature exceeds the authorized limit > 85°C.	<input checked="" type="checkbox"/>	Y	The pump can not restart.	<ul style="list-style-type: none"> Check that the ventilation is operating (air admission not blocked). Provide more space around the controller.
D 24: PUMP TEMP.	The controller temperature exceeds the authorized limit $\geq 85^{\circ}\text{C}$.	<input checked="" type="checkbox"/>	N	The controller stops the motor as long as the temperature exceeds 30° C. Then the motor starts again.	<ul style="list-style-type: none"> Check that the pump cooling device is running.
D 26: NO CONNECT	Wiring fault between pump and controller (connection cable).	<input checked="" type="checkbox"/>	Y	The pump can not start.	<ul style="list-style-type: none"> Check that the cable is correctly locked to the pump and the controller. If the fault appears again, ① Contact the Customer Service
D 35: DPRAM MAG	Mechanical or electrical problem.	<input checked="" type="checkbox"/>	Y	No magnetic levitation, the pump can not start.	<ul style="list-style-type: none"> Reinitialize the controller.

Diagnosis and troubleshooting

Several defects appear:

Incident	Cause	Remedy
D 11 - D 26 - D 35	The pump is not connected to the controller.	<ul style="list-style-type: none"> Check that the cable between pump and controller is correctly connected.

Fault is not indicated by the controller

Incident	Cause	Remedy
No even occurs after power on <div style="background-color: yellow; border: 1px solid black; padding: 5px; display: inline-block;">  CAUTION </div>	▶ No mains current. <div style="border: 1px solid yellow; padding: 5px; display: inline-block;"> Isolate the product from the various energy sources before any maintenance operations. </div>	<ul style="list-style-type: none"> Check that the controller is powered. Check that the power voltage is between 200 V AC - 10 % and 240 V AC + 10 % . ① Contact the Customer Service.
The pump only starts in STANDBY mode	▶ Electrical problem.	<ul style="list-style-type: none"> Pump stopped, reinitialize the controller with the main switch (0/1). ① Contact the Customer Service.
The pump starts to vibrate	▶ Mechanical problem.	<ul style="list-style-type: none"> Check that the pump is rigidly fixed to the frame. Check that there are no vibrations on the Pump frame. Check that the attachment are correctly fastened (problem can be caused by an anti-vibration flagstone). ① Contact the Customer Service.
The pump does not reach the expected speed	▶ Leak on the installation.	<ul style="list-style-type: none"> Close the chamber isolation valve. Start the pump. If the pump reaches the expected speed: the leak is in the chamber.

Diagnosis and troubleshooting

Incident	Cause	Remedy
The pump does not reach the expected speed (Cdt.)	▶ Exhaust isolation valve stays closed.	<ul style="list-style-type: none"> • If the valve is controlled by the «START» contact, check that the valve opens when the «START» is selected. • If the valve doesn't open, check the coil and electrical connection. • Check on the controller the closing of the «START» contact (valve disconnected). • If the contact does not close, then ① Contact Customer Service.
	▶ Defective rough pumping.	<ul style="list-style-type: none"> • Install a gauge at the primary pump inlet and check its vacuum limit ($P \leq 1.10^{-1}$ mbar).
	▶ Air inlet valve stays opened	<ul style="list-style-type: none"> • Controller powered, valve disconnected from the controller, check the «AIR» output voltage (0 V). • Check the air valve operation (NC). • If the output is defective, then ① Contact Customer Service.
	▶ Leak on the air inlet valve.	<ul style="list-style-type: none"> • Replace the valve with a blank off. Be careful: the pump is no more protected against corrosive gases. • Start the pump. • If the pump reaches its speed, stop it quickly and exchange the valve. • ① Contact Customer Service.
The thermostatic temperature is not reached	▶ The heating band does not heat.	<ul style="list-style-type: none"> • Close the water line. If the temperature increases, there is a leak in the water line. • Check that the «THERMOSTAT» contact are closed. • Check the heating band power supply. • ① Contact Customer Service.
«...waiting HEAT ...» after 1h30		<ul style="list-style-type: none"> • Check that the water valve output is supplied with 24 V DC and the water valve is not open.



Appendix

Operating instructions MAGPOWER Controller Detailed contents

G 100

Declaration of conformity

DECLARATION OF CE CONFORMITY

We, adixen Vacuum Products
98, Avenue de Brogny, BP 2069
74009 ANNECY FRANCE

ISO 9001 CERTIFIED

declare under our sole responsibility that the following products

MAGPOWER with ATP 2300M
MAGPOWER with ATH 1300M / ATH 1300MT
MAGPOWER with ATH 1600M / ATH 1600MT
MAGPOWER with ATH 2300M / ATH 2300MT
MAGPOWER with ATH 2303M / ATH 1603M
MAGPOWER with ATH 2800M / ATH 2800MT
MAGPOWER with ATH 3200M / ATH 3200MT

to which this declaration relates are in conformity with the relevant provisions of the following European Directives:

1998 / 37 / EEC : MACHINERY DIRECTIVE

2006 / 95 / EEC : LOW VOLTAGE DIRECTIVE

2004/ 108 / EEC : ELECTROMAGNETIC COMPATIBILITY

2002/95/EEC : RESTRICTION OF HAZARDOUS SUBSTANCES

when used in accordance with the instruction manual of the product.

Implemented standards

NF EN 61010-1
 NF EN 61000-6-2
 NF EN 61000-6-4

Those products comply with the relevant provisions of the above Directives and carry the CE marking.

Signatures:

Anancy August 12, 2011

Authorized person to compile the relevant technical documentation:



Mr Eric TABERLET
President



Mr Gilles BARET
Director of Products and Technology
98, Avenue de Brogny, BP 2069 74009 Anancy, France

LANGUAGE : English

**Leading. Dependable.
Customer Friendly.**

Pfeiffer Vacuum stands for innovative and custom vacuum solutions worldwide. For German engineering art, competent advice and reliable services.

Even since the invention of the turbopump, we've been setting standards in our industry. And this claim to leadership will continue to drive use in the future.

**You are looking for a
perfect vacuum solution?
Please contact us:**

Pfeiffer Vacuum Products GmbH
Berliner Strasse 43
35614 Asslar - Germany
T +49 6441 802-0
F +49 6441 802-202
Info@pfeiffer-vacuum.de
www.pfeiffer-vacuum.de

adixen Vacuum Products
98 avenue de Brogny
74009 Annecy Cedex - France
T +33 (0) 4 50 65 77 77
F +33 (0) 4 50 65 77 89
info@adixen.fr
www.adixen.com

